

fd dmx 3-24e 350

350mA RGB DMX LED dimmer

Digital RGB LED dimmer with three 350mA constant current outputs for smooth control, especially in lower dimming range.

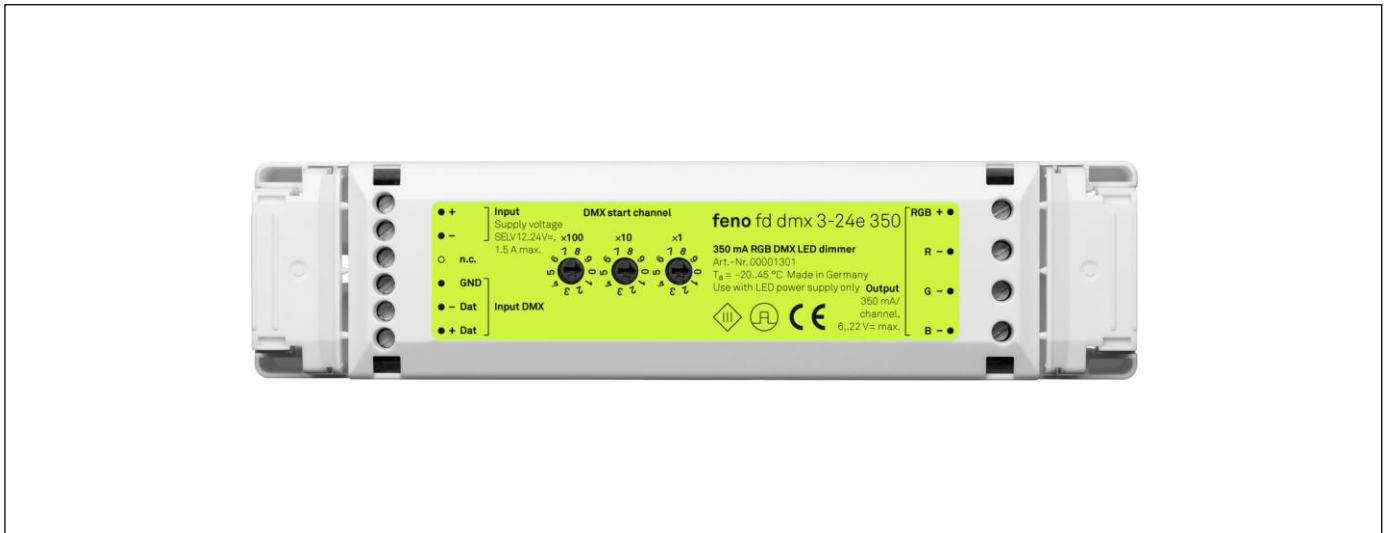

Properties

- Robust constant current dimmer for LED modules without own current limiter
- Protected against short-circuit and overtemperature
- Smooth dimming control even in the lowest range
- Dimming curve matched to eye sensitivity
- Digital control with DMX control devices
- Start channel easily adjustable via rotary switch
- Plastic housing construction with cable grip

Ordering Information

Product name	fd dmx 3-24e 350
Item number	0000 1301

Available Versions



fd dmx 3-24e 500



fd dmx 3-24e 700

Combinable with the following feno products



fc s.dmx 48d



fc s.dmx 144d



fc dmx 512u

fd dmx 3-24e 350

350mA RGB DMX LED dimmer

Wiring Diagram

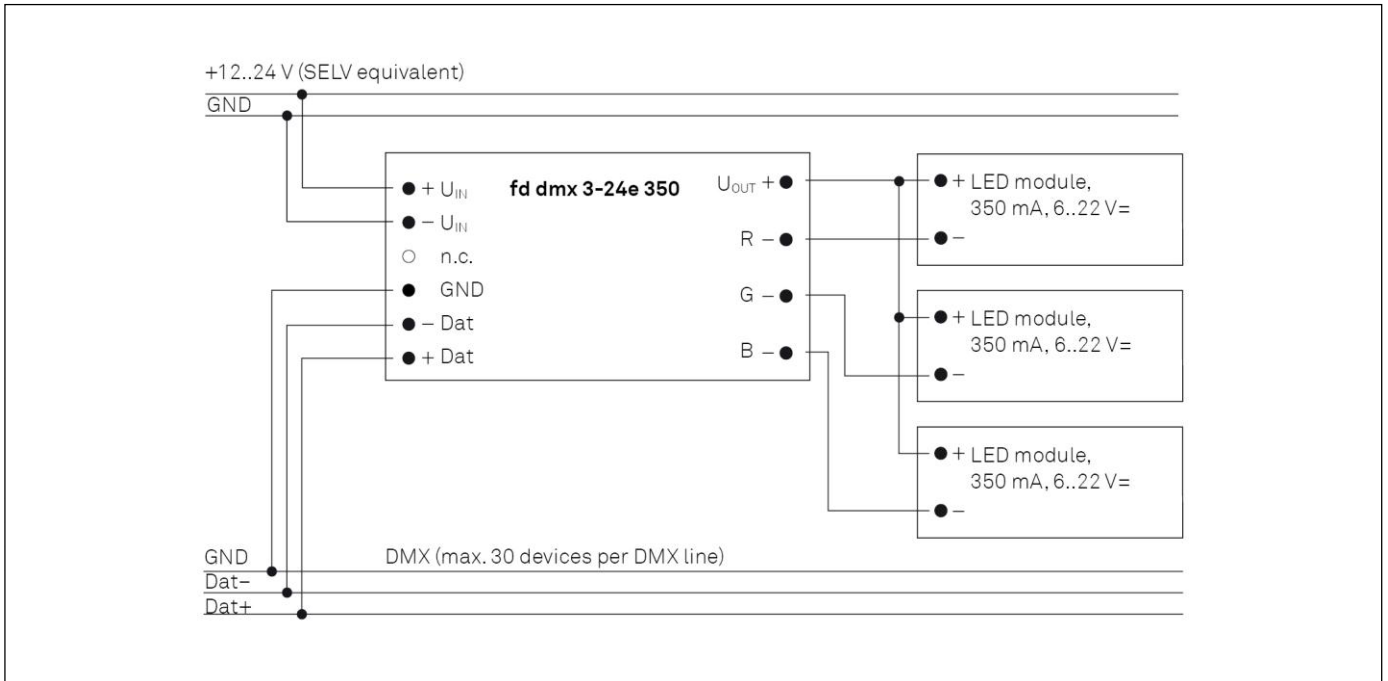

Technical Details

Supply voltage	12..24 V DC (SELV)
Power consumption	1,5 A max.
Control inputs	1
Control signal	DMX
Operating mode	Constant current
Outputs	3
Dimming frequency / internal	120 Hz/16 Bit
Output voltage	6..22 V DC
Output load	3 x 350 mA
Outputs short circuit proof	yes
Ambient temperature	-20..45 °C
Dimensions (L/W/H)	167 x 42 x 31 mm
Weight	90 g

Standards

EN 61347-1
 EN 61347-2-11
 EN 61347-2-13
 EN 55015
 EN 61547
 EN 61000-3-2
 EN 61000-3-3