

IP20     RoHS

TALEXconverter LCCI 16 W TALEXconverter REMOTE LCI

Product description

- 350, 500 or 700 mA output signal
- Over temperature protection with current back control
- Cage clamp terminals for rigid and flexible wires
- Double assignment of the terminal possible
- Rapid installation of cable clamp and terminal cover, no tool required
- Connecting cable, cable cross-section 0.5 – 2.5 mm²
- Output power 16 W
- Protection class 2, SELV
- Type of protection IP20
- Converters for individual luminaires

Properties

- Casing: polycarbonate, black
- Large connection compartment
- Adjustable output current via potentiometer or resistor[Ⓜ]
- Compact dimensions

Technical data

Rated supply voltage	220 – 240 V
Input voltage, AC	198 – 264 V
Rated current (at 230 V 50 Hz)	0.15 A
Mains frequency	50 / 60 Hz
Efficiency at full load	> 85 %
Max. input power	20 W
λ	> 0.5 C
Potentiometer	100 kOhm, linear [Ⓜ]
Output power	16 W
Output power range	1 – 16 W
Startzeit	< 100 ms
Ambient temperature ta	-25 ... +55 °C
Max. casing temperature tc	75 °C
Weight	0.08 kg
Dimensions LxWxH	101.5 x 51 x 29.5 mm

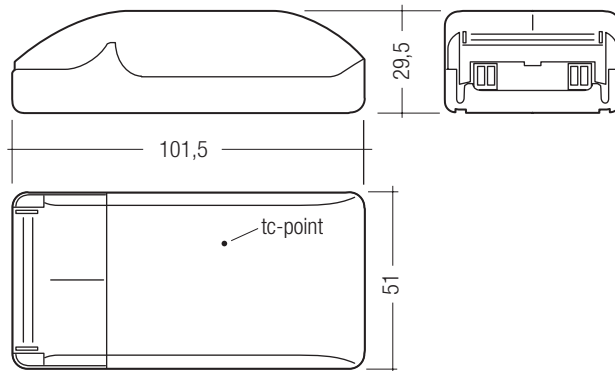

Ordering data

Type	Article number
LCCI 016/0350 B020	86459210
LCCI 016/0500 B020	86459211
LCCI 016/0700 B020	86459212

Packaging: 24 pieces/carton, 1200 pieces/pallet

Specific technical data

Type	Output current range [Ⓜ]	Output voltage range
LCCI 016/0350 B020	70 – 350 mA	3 – 48 V
LCCI 016/0500 B020	100 – 500 mA	3 – 33 V
LCCI 016/0700 B020	140 – 700 mA	3 – 24 V

[Ⓜ] Each converter must be adjusted by a separate potentiometer. It is not allowed to adjust more than one converter by one potentiometer.

[Ⓜ] For details please refer to page 2: "Output current according to resistance"

Standards

- EN 55015
- EN 61000-3-2
- EN 61000-3-3
- EN 61347-1
- EN 61347-2-13
- EN 61547
- EN 62384

Installation instructions

Please note that LCCI 016 complies with protection class II so special measures are needed if it is to be installed in protection class I applications / luminaires.
 Please note the requirements set out in the document LED_Betriebsgeraete_installationshinweis.pdf (<http://www.tridonic.com/com/de/technische-doku.asp>).

Maximum loading of automatic circuit breakers

Automatic circuit breaker type	C10	C13	C16	C20	B10	B13	B16	B20
Installation Ø	1.5mm ²	1.5mm ²	1.5mm ²	2.5mm ²	1.5mm ²	1.5mm ²	1.5mm ²	2.5mm ²
LCCI 016/0350 B020	30	40	50	60	15	20	25	30
LCCI 016/0500 B020	30	40	50	60	15	20	25	30
LCCI 016/0700 B020	30	40	50	60	15	20	25	30

Wiring diagram

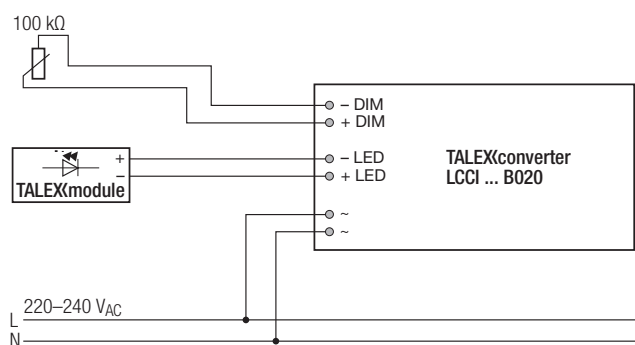

Wiring type and cross section

The wiring can be in flexible cable with ferules or solid. For perfect function of the cage clamp terminals the strip length should be 7.5–8.5 mm for the input terminal.

The max. torque at the clamping screw (M3) is 0.5 Nm.

Input / Output terminal

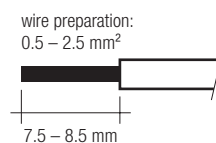

Output current according to resistance

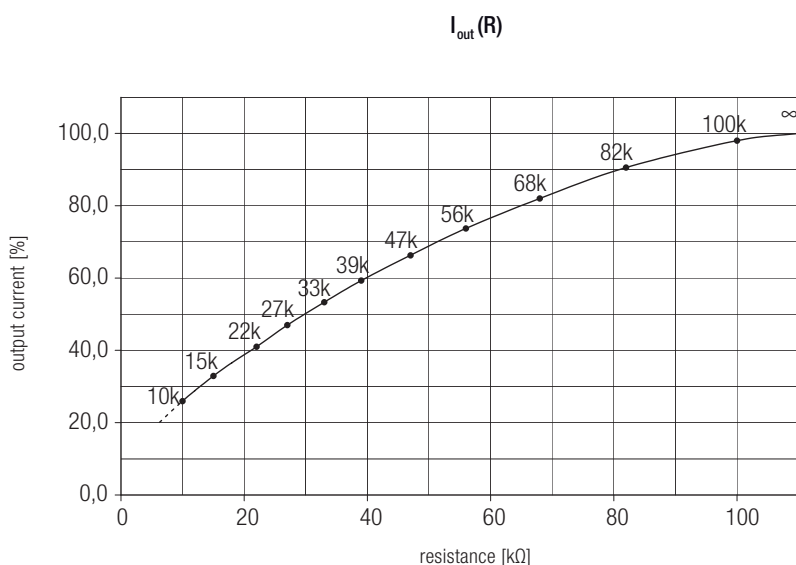

Used resistor range E12

Component tolerances are not considered in the diagram