

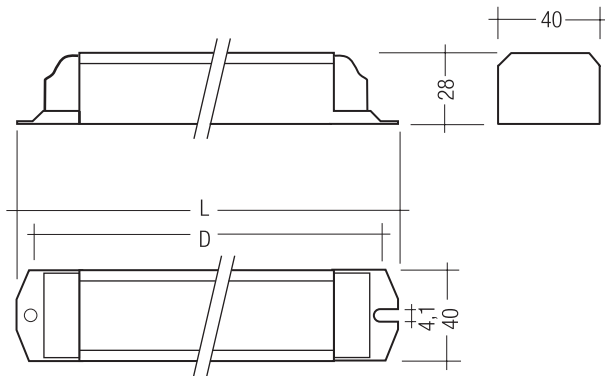

### PC T8 PRO, 70 W PC PRO T8

#### Product description

- CELMA Energy Efficiency Index A2
- Nominal life-time up to 50,000 h (at ta 50 °C with a failure rate max. 0.2 % per 1,000 h)
- Large temperature range (for values see table)
- Intelligent Voltage Guard (overvoltage indication and undervoltage shutdown)
- Constant luminous flux irrespective of fluctuations in mains voltage
- For luminaires of protection class I and protection class II
- Automatic start after replacement of defective lamps
- Safety shutdown of defective lamps and at end of lamp life
- Insulation Displacement Connection (IDC) terminal for rapid automatic or manual wiring
- For emergency lighting systems as per EN 50172
- For luminaires with F or M and MM as per EN 60598, VDE 0710 and VDE 0711
- Temperature protection as per EN 61347-2-3 C5e
- 5 years guarantee



#### Technical data

AC voltage range	198 – 264 V
DC voltage range	176 – 280 V (Lamp start $\geq$ 198 V DC)
Overvoltage protection	320 V AC, 1 h
Defined warm start	$\leq$ 1.5 s
Operating frequency	$\geq$ 40 kHz
Type of protection	IP20

#### Ordering data

Type	Article number	Packaging carton	Packaging pallet	Weight per pc.
<b>For luminaires with 1 lamp</b>				
PC 1/70 T8 PRO	87500513	28 pc(s).	560 pc(s).	0.199 kg
<b>For luminaires with 2 lamps</b>				
PC 2/70 T8 PRO	87500523	28 pc(s).	336 pc(s).	0.313 kg



Standards, page 3

Wiring diagrams and installation examples, page 5

#### Specific technical data

Lamp wattage	Lamp type	Type	Article number	Dimensions L x W x H	Hole spacing D	Lamp power	Circuit power	EEI	Current at 50 Hz		$\lambda$ at 50 Hz		tc point max.	Ambient temperature ta
									220 V	240 V	220 V	240 V		
<b>For luminaires with 1 lamp</b>														
1 x 70 W	T8	PC 1/70 T8 PRO	87500513	234 x 40 x 28 mm	220 mm	60 W	65.6 W	A2	0.30 A	0.28 A	0.99	0.98	75 °C	-25 ... 55 °C
<b>For luminaires with 2 lamps</b>														
2 x 70 W	T8	PC 2/70 T8 PRO	87500523	360 x 40 x 28 mm	350 mm	120 W	136.8 W	A2	0.62 A	0.57 A	0.99	0.99	70 °C	-25 ... 50 °C

### Standards

EN 55015  
EN 61347-2-4  
EN 61347-2-3  
EN 60929  
EN 61000-3-2  
EN 61547  
in accordance with EN 50172  
IEC 68-2-64 Fh  
IEC 68-2-29 Eb  
IEC 68-2-30

### Lamp starting characteristics

Warm start  
Starting time 1.5 sec. with AC and DC operation  
Cathode heating will be reduced after preheat time

### AC operation

Mains voltage:  
220–240 V 50/60 Hz  
198–264 V 50/60 Hz including safety tolerance ( $\pm 10\%$ )  
202–254 V 50/60 Hz including performance tolerance ( $+6\% / -8\%$ )

### DC operation

220–240 V 0 Hz  
198–280 V 0 Hz certain lamp start  
176–280 V 0 Hz operating range  
Light output level in DC operation: 100 %

### Emergency lighting

Use in emergency lighting installations according to EN 50172 or for emergency luminaires according to EN 61347-2-3 appendix J.

Instant start after mains interruption  $< 0.5$  s  
EBLF  $\geq 0.5$

### Intelligent Voltage Guard

Intelligent Voltage Guard is the name of the new electronic monitor from Tridonic. This innovative feature of the PC PRO family of control gear from Tridonic immediately shows if the mains voltage rises above or falls below certain thresholds. Measures can then be taken quickly to prevent damage to the control gear.

- If the mains voltage rises above approx. 306 V (voltage depends on the ballast type), the lamp starts flashing on and off.
- This signal "demands" disconnection of the power supply to the lighting system.
- If the mains voltage falls below 150 V the control gear automatically disconnects the lamp circuit to protect the control gear from being irreparably damaged.

### Smart Heating

Innovative heating circuit. Reduced filament heating after lamp has struck.

### Mains currents in DC operation

Type	Lamp type	Wattage	Mains current at $U_n = 220 V_{DC}$	Mains current at $U_n = 240 V_{DC}$
PC 1/70 T8 PRO	T8	1x70 W	0.30 A	0.28 A
PC 2/70 T8 PRO	T8	2x70 W	0.61 A	0.57 A

### Harmonic distortion in the mains supply

Type	Lamp type	Wattage	THD at 230 V / 50 Hz
PC 1/70 T8 PRO	T8	1x70 W	$< 10\%$
PC 2/70 T8 PRO	T8	2x70 W	$< 10\%$

### Working voltage

Type	Lamp type	Wattage	$U_{out}$
PC 1/70 T8 PRO	T8	1x70 W	250 V
PC 2/70 T8 PRO	T8	2x70 W	250 V

### Ballast lumen factor (EN 60929 8.1)

Type	Lamp type	Wattage	AC/DC-BLF at $U = 198-254 V, 25^\circ C$
PC 1/70 T8 PRO	T8	1x70 W	1.00
PC 2/70 T8 PRO	T8	2x70 W	1.00

**PC PRO with xitec processor**

Is the very latest in lighting management design technology. The lamp friendly warm start is delivering maximum T8 lamp life and enables high switching frequency applications. Smallest power loss and new freedom in the lamp design thanks to convincing thermal management.

**Energy class CELMA EEI = A2<sup>1)</sup>**

PC T8 PRO ignition technology (smart heating) optimises lamp start and ensures no energy is wasted. After the lamp has struck the filament heating is reduced automatically to a defined minimum value. This reduction in filament heating, saves energy, yet maintains the proper operating conditions for the lamp. The lamp is always operated within specification.

<sup>1)</sup> according to the EU directives on ecodesign requirements (EC) No. 245/2009 and (EC) No. 347/2010

**PC 1/70 T8 PRO**

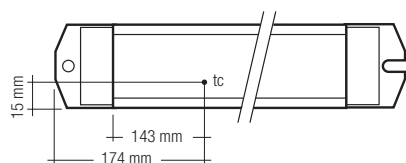

**Ambient Temperature**

-25 °C to +50 °C resp. 55 °C resp. 60 °C

The nominal  $t_a$  and  $t_c$  point are related to the ballast life duration.

The relation of  $t_c$  to  $t_a$  temperature depends also on the luminaire design. If the measured  $t_c$  temperature is approx. 5 K below  $t_c$  max.,  $t_a$  temperature should be checked and eventually critical components (e.g. ELCAP) measured.

Detailed information on request.

PC T8 PRO is designed for an average life-time of 50,000 hours under reference conditions and with a failure probability of less than 10 %. This corresponds to an average failure rate of 0.2 % for every 1,000 hours of operation.

Humidity: 5 % up to max. 85 %, not condensed (max. 56 days/year at 85 %)

Storage temperature: -40 °C up to max. +80 °C

The devices have to be within the specified temperature range ( $t_a$ ) before they can be operated.

**Expected life-time**

Type	Lamp type	Lamp wattage	$t_a$	40 °C	50 °C	55 °C	60 °C
PC 1x70 T8 PRO	T8	1x70 W	$t_c$	60 °C	70 °C	75 °C	x
			Life-time	> 100,000 h	70,000 h	50,000 h	x
PC 2x70 T8 PRO	T8	2x70 W	$t_c$	60 °C	70 °C	x	x
			Life-time	100,000 h	50,000 h	x	x

x = not permitted

**Maximum loading of automatic circuit breakers**

Automatic circuit	C10	C13	C16	C20	B10	B13	B16	B20
Installation Ø	1.5 mm <sup>2</sup>	1.5 mm <sup>2</sup>	1.5 mm <sup>2</sup>	2.5 mm <sup>2</sup>	1.5 mm <sup>2</sup>	1.5 mm <sup>2</sup>	1.5 mm <sup>2</sup>	2.5 mm <sup>2</sup>
<b>PC 1/70 T8 PRO</b>	20	26	34	42	10	13	17	21
<b>PC 2/70 T8 PRO</b>	10	14	18	20	5	7	9	10

**Wiring advice**

The lead length is dependant on the capacitance of the cable. For safety reasons, the PC T8 PRO must only be earthed in the case of a safety class 1 luminaire. Earthing is not required for the device to operate. Connection to earth reduces radio interference.

With standard solid wire 0.5/0.75 mm<sup>2</sup> the capacitance of the lead is approx. 80 pF/m. This value is influenced by the way the wiring is made. In borderline cases the capacitance must be measured inside the luminaire. Keep lamp wires short. Lamp connection with twin ballast should be made with symmetrical wiring. Hot leads and cold leads should be separated as much as possible.

Ballast Type	Terminal	Maximum capacitance allowed			
		Cold	Hot	Kalt	Heiß
PC 1xx T8 PRO		11, 12	9, 10	200 pF	100 pF
PC 2xx T8 PRO		11, 12, 13, 14	9, 10	200 pF	100 pF

To avoid the damage of the control gear, the wiring must be protected against short circuits to earth (sharp edged metal parts, metal cable clips, louver, etc.)

**Installation instructions**

**IDC interface**

- solid wire with a cross section of 0.5 mm<sup>2</sup> according to the specification from WAGO

**Horizontal interface**

- solid wire with a cross section of 0.5–1.5 mm<sup>2</sup> according to the specification from WAGO
- strip 7.5–8.5 mm of insulation from the cables to ensure perfect operation of the push terminals

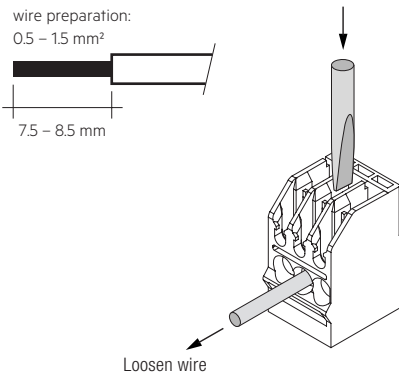

**Defective lamp**

If a lamp is defective, the ballast switches off and goes into standby. There is an automatic restart once the lamp has been changed.

**Insulation and electric strength testing of luminaires**

Electronic devices can be damaged by high voltage. This has to be considered during the routine testing of the luminaires in production.

According to IEC 60598-1 Annex Q (informative only!) or ENEC 303-Annex A, each luminaire should be submitted to an insulation test with 500 V<sub>DC</sub> for 1 second. This test voltage should be connected between the interconnected phase and neutral terminals and the earth terminal.

The insulation resistance must be at least 2 MΩ.

As an alternative, IEC 60598-1 Annex Q describes a test of the electrical strength with 1500 V<sub>AC</sub> (or 1.414 x 1500 V<sub>DC</sub>). To avoid damage to the electronic devices this test must not be conducted.

**RFI**

Tridonic ballasts are RFI protected in accordance with EN 55015:2006 and A1:2007. To operate the luminaire correctly and to minimise RFI we recommend the following instructions:

- Connection to the lamps of the “hot leads” must be kept as short as possible (marked with \*)
- Mains leads should be kept apart from lamp leads (ideally 5–10 cm distance)
- Do not run mains leads adjacent to the electronic ballast
- Twist the lamp leads
- Keep the distance of lamp leads from the metal work as large as possible
- Connect functional earth, either over the terminal or over the mounting screw of the ballast
- Mains wiring to be twisted when through wiring
- Keep the mains leads inside the luminaire as short as possible

**Additional information**

Additional technical information at [www.tridonic.com](http://www.tridonic.com) → Technical Data

Guarantee conditions at [www.tridonic.com](http://www.tridonic.com) → Services

Life-time declarations are informative and represent no warranty claim.

No warranty if device was opened.

**T8 lamp information**

	wattage	length
	30 W	900 mm
	36 W	1200 mm
	70 W	1800 mm

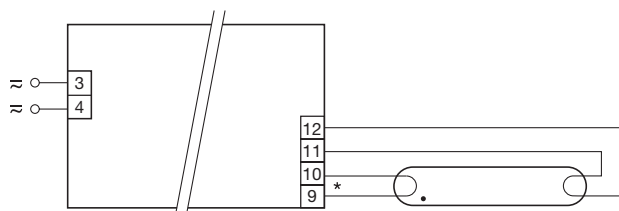

\* leads 9, 10 max. 1.0 m (< 100 pF)  
leads 11, 12 max. 2.0 m (< 200 pF)  
For luminaires of protection class I: Earthing via ECG casing (according to IEC 60598)  
For luminaires of protection class II: No earthing required

**PC 1x30-70 W T8 PRO**

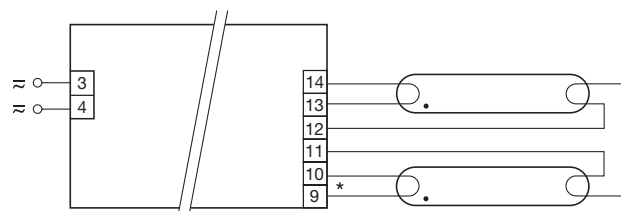

\* leads 9, 10 max. 1.0 m (< 100 pF)  
leads 11, 12, 13, 14 max. 2.0 m (< 200 pF)  
For luminaires of protection class I: Earthing via ECG casing (according to IEC 60598)  
For luminaires of protection class II: No earthing required

**PC 2x30-70 W T8 PRO**