

### PCIS, PCI, PCS outdoor FOX B011 PCI outdoor

#### Product description

- Pulse packets for increased ignition energy (pulseCONTROL technology)
- Flicker-free light
- Colour stability thanks to constant power
- No acoustic resonance
- Safety shutdown if a lamp is faulty or missing
- Greatly reduced reignition time
- Hardly any EMC interference in the ignition phase
- Screw terminals:  $\leq 1.5 \text{ mm}^2$  for stranded wire,  $\leq 2.5 \text{ mm}^2$  for solid wire
- Switching possible via mains or powerless via the digital interface
- Noise-free precise control via DALI or DSI signal
- Fault reporting in DALI mode
- Enhanced protection against mains transients
- Enhanced insulation
- Unit fully encased to protect against dust, moisture and vibration
- Casing: polycarbonate, black

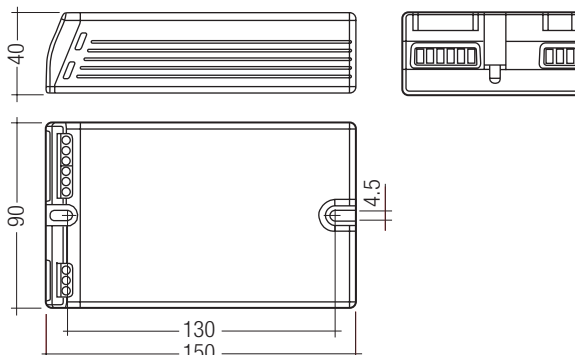

#### Technical data

Mains voltage range	220 – 240 V
AC voltage range	198 – 254 V
Mains frequency	50 / 60 Hz
Max. ignition voltage PCI, PCIS	5 kVp
Max. ignition voltage PCS	2.5 kVp
Operating frequency	145 Hz
Type of protection	IP20



Standards, page 2

Wiring diagrams and installation examples, page 2

#### Ordering data

Type	Article number	Packaging, carton	Packaging, pallet	Weight per pcs.
<b>For luminaires with 1 lamp</b>				
PCI 45 outdoor FOX B011	86459331	16 pc./pcs.	480 pc./pcs.	0.700 kg
PCI 50 outdoor FOX B011	86459334	16 pc./pcs.	480 pc./pcs.	0.700 kg
PCS 50 outdoor FOX B011	86459333	16 pc./pcs.	480 pc./pcs.	0.700 kg
PCI 60 outdoor FOX B011	86459155	16 pc./pcs.	480 pc./pcs.	0.712 kg
PCI 70 outdoor FOX B011	86458590	16 pc./pcs.	480 pc./pcs.	0.714 kg
PCS 70 outdoor FOX B011	86458591	16 pc./pcs.	480 pc./pcs.	0.703 kg
PCI 90 outdoor FOX B011	86459156	16 pc./pcs.	480 pc./pcs.	0.749 kg
PCIS 100 outdoor FOX B011	86458592	16 pc./pcs.	480 pc./pcs.	0.748 kg
PCI 140 outdoor FOX B011	86459157	16 pc./pcs.	480 pc./pcs.	0.743 kg
PCIS 150 outdoor FOX B011	86458593	16 pc./pcs.	480 pc./pcs.	0.764 kg

#### Specific technical data

Lamp wattage	Lamp type	Type	Article number	Dimensions L x W x H	Lamp power	Circuit power <sup>①</sup>	EEL	Efficiency	Current at 50 Hz 230 V	$\lambda$ at 50 Hz 230 V	Max. cable length to lamp	tc point max.	Ambient temperature ta	tc/ta for $\geq 60,000 \text{ h}$
<b>For luminaires with 1 lamp</b>														
1 x 45 W	HI	PCI 45 outdoor FOX B011	86459331	150 x 90 x 40 mm	45 W	52 W	A2	> 88 %	0.23 A	0.97	5 m / 400 pF	70 °C	-25 ... +60 °C	70/60 °C
1 x 50 W	HI	PCI 50 outdoor FOX B011	86459334	150 x 90 x 40 mm	50 W	57 W	A2	> 88 %	0.25 A	0.97	5 m / 400 pF	70 °C	-25 ... +60 °C	70/60 °C
1 x 50 W	HS	PCS 50 outdoor FOX B011	86459333	150 x 90 x 40 mm	50 W	57 W	A2	> 88 %	0.25 A	0.97	5 m / 400 pF	70 °C	-25 ... +60 °C	70/60 °C
1 x 60 W	HI	PCI 60 outdoor FOX B011	86459155	150 x 90 x 40 mm	60 W	68 W	A2	> 88 %	0.30 A	0.97	5 m / 400 pF	70 °C	-25 ... +60 °C	70/60 °C
1 x 70 W	HI	PCI 70 outdoor FOX B011	86458590	150 x 90 x 40 mm	73 W	81 W	A2	> 88 %	0.35 A	0.97	5 m / 400 pF	70 °C	-25 ... +55 °C	70/55 °C
1 x 70 W	HS	PCS 70 outdoor FOX B011	86458591	150 x 90 x 40 mm	73 W	81 W	A2	> 88 %	0.35 A	0.97	5 m / 400 pF	70 °C	-25 ... +55 °C	70/55 °C
1 x 90 W	HI	PCI 90 outdoor FOX B011	86459156	150 x 90 x 40 mm	90 W	99 W	A2	> 91 %	0.45 A	0.97	5 m / 400 pF	70 °C	-25 ... +55 °C	70/55 °C
1 x 100 W	HI & HS	PCIS 100 outdoor FOX B011	86458592	150 x 90 x 40 mm	100 W	109 W	A2	> 91 %	0.50 A	0.97	5 m / 400 pF	70 °C	-25 ... +55 °C	70/55 °C
1 x 140 W	HI	PCI 140 outdoor FOX B011	86459157	150 x 90 x 40 mm	140 W	155 W	A2	> 91 %	0.65 A	0.97	5 m / 400 pF	75 °C	-25 ... +55 °C	75/55 °C
1 x 150 W	HI & HS	PCIS 150 outdoor FOX B011	86458593	150 x 90 x 40 mm	147 W	161 W	A2	> 91 %	0.70 A	0.97	5 m / 400 pF	75 °C	-25 ... +55 °C	75/55 °C

① At ta = 25 °C.

**Installation instructions**

**Wiring type and cross section**

Stranded wire with end ferrule with a cross section of 1.5 mm<sup>2</sup> or solid wire up to 2.5 mm<sup>2</sup> may be used for wiring. Strip 6 mm of insulation from the cables to ensure perfect operation of the screw terminals.

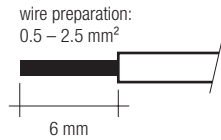

**Note on wiring**

The length of the lamp wires is limited by the value of cable capacitance. The maximum of 400 pF would enable connection of approximately 5 metres of lamp wire.

To avoid the damage of the control gear, the wiring must be protected against short circuits to earth (sharp edged metal parts, metal cable clips, louver, etc.).

In class 1 luminaires it is necessary to earth the ballast and the luminaire via the earth terminal.

Protection class 2 luminaires do not need an earth connection. Insulation must be provided by the luminaire design.

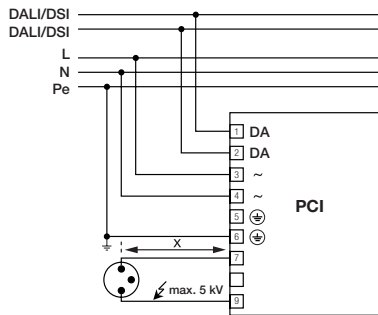

Circuit diagram PCIS class 1 application

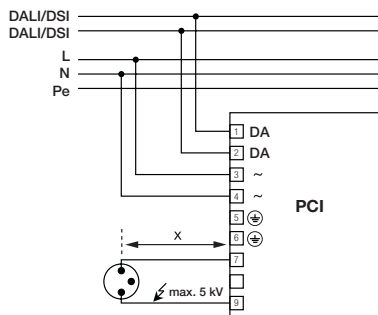

Circuit diagram PCIS class 2 application

**Radio interference**

- Do not cross mains and lamp cables.
- Do not lay mains cables together with lamp cables (ideally they should be 5–10 cm apart).
- Do not lead mains cables too closely along the electronic ballast.
- Twist lamp cables.
- Increase the distance between lamp cables and earthed metal surfaces.
- Keep the mains cable in the luminaire short.
- Parallel runs (x) of mains and lamp cables must be kept as short as possible.

**Mounting recommendation**

To ensure optimum heat removal the ECG should be mounted on a metal plate (luminaire body). No insulators between the ECG and the the cooling surface (air, adhesive tape, etc.). Finally, the temperature measurement remains important.

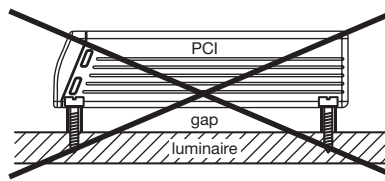
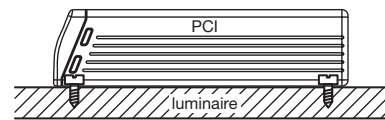

If several ballasts are installed in masts, boxes, etc., measures must be taken to avoid overheating of individual components.

**Harmonic distortion in the mains supply**

Type	THD
PCI 45 outdoor FOX B011	< 10 %
PCI 50 outdoor FOX B011	< 10 %
PCS 50 outdoor FOX B011	< 10 %
PCI 60 outdoor FOX B011	< 10 %
PCI 70 outdoor FOX B011	< 10 %
PCS 70 outdoor FOX B011	< 10 %
PCI 90 outdoor FOX B011	< 10 %
PCIS 100 outdoor FOX B011	< 10 %
PCI 140 outdoor FOX B011	< 10 %
PCIS 150 outdoor FOX B011	< 10 %

**Ballast lumen factor EN 60929 8.1**

Type	AC/DC-BLF at U = 198–254 V, 25 °C
PCI 45 outdoor FOX B011	1.00
PCI 50 outdoor FOX B011	1.00
PCS 50 outdoor FOX B011	1.00
PCI 60 outdoor FOX B011	1.00
PCI 70 outdoor FOX B011	1.00
PCS 70 outdoor FOX B011	1.00
PCI 90 outdoor FOX B011	1.00
PCIS 100 outdoor FOX B011	1.00
PCI 140 outdoor FOX B011	1.00
PCIS 150 outdoor FOX B011	1.00

**Safety switch off**

**End of life of the lamps**

At the end of their useful life, lamps often cycle on/off. The PCIS ballast recognises this condition and switches off the lamp, after three complete on/off cycles and whilst the supply has been unswitched. Complete lamp switch-off enables easy identification of a defective lamp in the application. After a change of the faulty lamp and an interruption of the mains supply (mains reset) or send a ON-OFF sequence the ballast will strike the lamp. When there is no lamp in circuit or a defective lamp is connected to the ballast, the ballast will switch off after appr. 25 minutes.

**Overtemperature shutdown**

The ballasts are equipped with a thermal shutdown to protect against destruction. After shutdown they can be restored with an OFF-ON sequence via DALI/DSI or with a mains reset.

**Overload strength**

320 V AC / 1 h

**Important advise**

When a lamp is changed (at the end of its life), if a lamp is missing, or after overtemperature shutdown the mains voltage of the ECG must be disconnected. Alternatively an OFF ON sequence can be sent.

**Warning – starting voltage up to max. 5 kV!**

Not suitable for use with lamps with integral ignitors. A list of released lamps for the save operation with PCIS can be found on [www.tridonic.com](http://www.tridonic.com) → Technical Data → Lamp matrix → Lamp Matrix for HID

**Standards**

- EN 55015 (radio interference)
- EN 61000-3-2 (mains harmonics)
- EN 61347-2-12
- EN 61547 (interference immunity)
- IEC 62368 (DALI standard)

**Transient protection**

Type	L/N-PE	L-N
PCI 45 outdoor FOX B011	4kV	6kV
PCI 50 outdoor FOX B011	4kV	6kV
PCS 50 outdoor FOX B011	4kV	6kV
PCI 60 outdoor FOX B011	4kV	6kV
PCI 70 outdoor FOX B011	4kV	6kV
PCS 70 outdoor FOX B011	4kV	6kV
PCI 90 outdoor FOX B011	4kV	6kV
PCIS 100 outdoor FOX B011	4kV	6kV
PCI 140 outdoor FOX B011	4kV	6kV
PCIS 150 outdoor FOX B011	4kV	6kV

according to EN 61000-4-5. Protected against a single 10kV pulse.

### Loading of automatic circuit breakers

Automatic circuit breaker type	C10	C13	C16	C20	B10	B13	B16	B20
Installation Ø	1.5 mm <sup>2</sup>	1.5 mm <sup>2</sup>	1.5 mm <sup>2</sup>	2.5 mm <sup>2</sup>	1.5 mm <sup>2</sup>	1.5 mm <sup>2</sup>	1.5 mm <sup>2</sup>	2.5 mm <sup>2</sup>
PCI 45 outdoor FOX B011	14	25	36	42	8	14	25	30
PCI 50 outdoor FOX B011	14	25	36	42	8	14	25	30
PCS 50 outdoor FOX B011	14	25	36	42	8	14	25	30
PCI 60 outdoor FOX B011	14	25	36	42	8	14	25	30
PCI 70 outdoor FOX B011	14	25	36	42	8	14	25	30
PCS 70 outdoor FOX B011	14	25	36	42	8	14	25	30
PCI 90 outdoor FOX B011	10	18	26	30	6	10	13	13
PCIS 100 outdoor FOX B011	10	18	26	30	6	10	13	13
PCI 140 outdoor FOX B011	7	14	20	20	4	6	7	7
PCIS 150 outdoor FOX B011	7	14	20	20	4	6	7	7

### Control via DALI/DSI

#### Control input (DA)

Digital DALI/DSI signal can be wired on the terminals DA.

#### Digital signal DALI/DSI

The control input is non-polar and protected against accidental connection with a mains voltage up to 264 V. The control signal is not SELV. Control cable should be installed in accordance with the requirements of low voltage installations. Different functions depending on each module.

#### Standards (DALI)

HID EVG → device type 2  
Switching device → device type 7  
DALI 0 = 0 % light  
DALI > 0 = 100 % light

#### Programmable parameters

- Groups 1–16
- Scenes 1–16 (values 0 % / 100 % / MASK)
- Power On Level (values 0 % / 100 %)
- System Failure Level (values 0 % / 100 %)

#### Queries

via DALI standard:

- Lamp wattage (values yes/no)
- Lamp error (values yes/no)

via Tridonic masterCONFIGURATOR:

- Lamp type
- Device type
- Article number
- Production date
- Serial number
- Software version
- Commissioning

#### OEM Memory Bank

The customer can store additional luminaire information in the ECG (Memory Bank 1), such as luminaire type and article number. Data is written to Memory Bank 1 in accordance with DALI standard IEC 62368.

### Commissioning of PCIS outdoor FOX ballasts

Because of the special characteristics of HID light sources, PCIS outdoor FOX ballasts cannot be addressed in the same way as conventional DALI ballasts for fluorescent or halogen lamps for example. For visualisation during the grouping phase the HID lamps must remain switched off before and during the addressing phase as they can only be properly ignited in the cold state. Dimmed operation of these lamps is not recommended, which also calls for different handling during commissioning.

Tridonic recommends masterCONFIGURATOR ≥ V2.0.0 software for commissioning PCIS outdoor FOX ballasts (download from [www.tridonic.com](http://www.tridonic.com) → Services → Software).

**IMPORTANT:** Other DALI controllers can only be used for commissioning if they handle DALI Device Type 2 units appropriately (see Requirements of control products).

### Requirements of control products

Initialization/addressing phase:

#### INITIALIZE

...

...

...

#### RECALL MIN LEVEL

...

...

...

#### TERMINATE

(This command must be sent first)  
When the INITIALIZE command is sent, PCIS outdoor DIM devices change the  
RECALL MIN value to 0 % → devices switch off/remain switched off  
(Last command in the initialization phase)  
When the TERMINATE command is sent, PCIS outdoor DIM changes the RECALL MIN value back to 40 % (100 % light)

The high ignition voltage of high pressure lamps can lead to interferences. During the ignition time the communication can be disturbed. Therefore the ballast might not react during the ignition phase. This has to be considered especially when using gateways.

### Realisation with Tridonic controls

	Commissioning	Operation
DALI GC		✓
x-touchPANEL	✓	✓
x-touchBOX	✓	✓
DALI TOUCHPANEL		✓
Software masterCONFIGURATOR	✓	✓

Overview – commissioning cycle with masterCONFIGURATOR ≥ V2.0.0

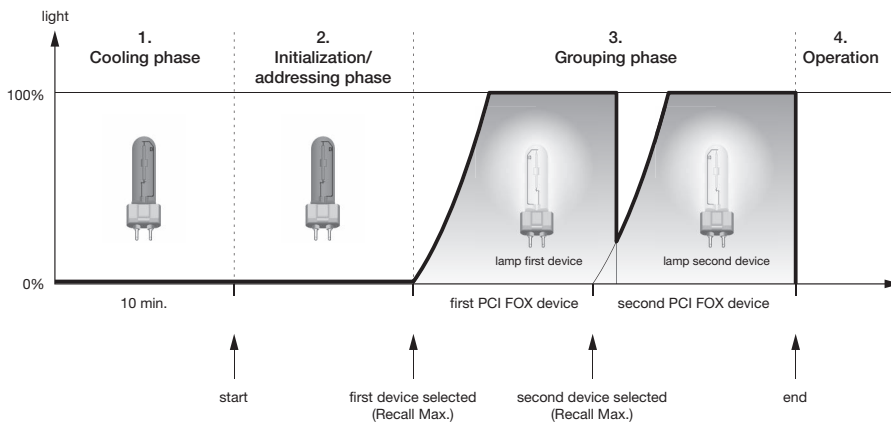

Step-by-step commissioning with masterCONFIGURATOR ≥ V2.0.0

1. Cooling phase

HID EVG → Device Type 2  
The lighting must have been switched off before start-up for at least 10 min.  
(visualization/grouping is not possible with hot lamps)

2. Initialisation and addressing phase

- Launch masterCONFIGURATOR
- Click on “Addressing wizard” and follow the on-screen instructions.

PCIS outdoor FOX devices remain dark during the entire addressing phase. In contrast, DALI devices for fluorescent lamps, LEDs and incandescent lamps fade down to their minimum value and go to 100 % during the addressing phase. At the end of the addressing phase they fade back to their minimum value.

3. Visualisation in the grouping phase

- Activate the “Enable optical selection feedback” by ticking the checkbox.
- If a PCIS outdoor FOX device (Device Type 2, special symbol) is selected in configTOOL the appropriate device switches on. It remains on until a different DALI device is selected in the system.  
→ PCIS outdoor FOX then switches off after a maximum delay of 10 seconds.

4. Operation

- PCIS outdoor FOX devices can be switched powerless with a broadcast signal (DALI or DSI, without addressing of the devices)
- PCIS outdoor FOX devices can be addressed and operated individually or in groups with a DALI signal. For examples with Tridonic controls please see matrix above.

Commissioning comparison table

	DALI HID ballast PCIS outdoor FOX	Standard DALI ballast e.g. PCA Excel one4all
Before commissioning the installation	Devices must have been switched off for at least 10 minutes!	–
Initialisation and addressing phase	Devices remain switched off	<ul style="list-style-type: none"> <li>• Devices fade to minimum value</li> <li>• On successful addressing the devices fade up to 100 %</li> <li>• At the end of the addressing phase the devices fade down to the minimum value</li> </ul>
Visualisation in the grouping phase	<ul style="list-style-type: none"> <li>• Selected device starts the lamp at 100 %</li> <li>• If a different device is selected the previously selected device switches off with a maximum delay of 10 s</li> </ul> <p><b>Visualisation/grouping is not possible with hot HID lamps!</b></p>	<ul style="list-style-type: none"> <li>• Selected device fades from minimum value to 100 %</li> <li>• If a different device is selected the previously selected device fades to the minimum value</li> </ul>
Operation	Devices can be controlled/operated with other DALI/DSI control products	Devices can be controlled/operated with other DALI/DSI control products

Storage conditions

Humidity: 5 % up to max. 85 %, not condensed (max. 56 days/year at 85 %)

Storage temperature: -40 °C up to max. +80 °C

The devices have to be within the specified temperature range (ta) before they can be operated.

Isolation and electric strength testing of luminaires

Electronic devices can be damaged by high voltage. This has to be considered during the routine testing of the luminaires in production.

According to IEC 60598-1 Annex Q (informative only) or ENEC 303-Annex A, each luminaire should be submitted to an isolation test with 500 V<sub>DC</sub> for 1 second. This test voltage should be connected between the interconnected phase and neutral terminals and the earth terminal.  
The isolation resistance must be at least 2 MΩ.

As an alternative, IEC 60598-1 Annex Q describes a test of the electrical strength with 1500 V<sub>AC</sub> (or 1.414 x 1500 V<sub>DC</sub>). To avoid damage to the electronic devices this test must not be conducted.

## Temperature range

The ta temperature value is the basis for specifying the rated life.

The relationship between the tc temperature and the ta temperature depends on the design of the luminaire.

PCIS outdoor B011 is designed for an average life of 60,000 hours under rated conditions, with a failure probability of less than 10%. This corresponds to an average failure rate of 0.2% per 1,000 hours of operation.

The specified tc temperature is the maximum permitted value (rated temperature according to EN 61347 -1). Above this safety-related value the thermal cutout protects the device against damage.

The expected lifetime values are shown in the following table. The tc values are the relevant values here.

### Expected lifetime

Type	Lamp type	Lamp power	ta	40 °C	50 °C	55 °C	60 °C
PCI 45 outdoor FOX B011	HI	1x45 W	tc	50 °C	60 °C	65 °C	70 °C
			Lifetime	> 100,000 h	> 100,000 h	80,000 h	60,000 h
PCI 50 outdoor FOX B011	HI	1x50 W	tc	50 °C	60 °C	65 °C	70 °C
			Lifetime	> 100,000 h	> 100,000 h	80,000 h	60,000 h
PCS 50 outdoor FOX B011	HS	1x50 W	tc	50 °C	60 °C	65 °C	70 °C
			Lifetime	> 100,000 h	> 100,000 h	80,000 h	60,000 h
PCI 60 outdoor FOX B011	HI	1x60 W	tc	50 °C	60 °C	65 °C	70 °C
			Lifetime	> 100,000 h	> 100,000 h	80,000 h	60,000 h
PCI 70 outdoor FOX B011	HI	1x70 W	tc	55 °C	65 °C	70 °C	x
			Lifetime	> 100,000 h	80,000 h	60,000 h	x
PCS 70 outdoor FOX B011	HS	1x70 W	tc	55 °C	65 °C	70 °C	x
			Lifetime	> 100,000 h	80,000 h	60,000 h	x
PCI 90 outdoor FOX B011	HI	1x90 W	tc	55 °C	65 °C	70 °C	x
			Lifetime	> 100,000 h	80,000 h	60,000 h	x
PCIS 100 outdoor FOX B011	HI/HS	1x100 W	tc	55 °C	65 °C	70 °C	x
			Lifetime	> 100,000 h	80,000 h	60,000 h	x
PCI 140 outdoor FOX B011	HI	1x140 W	tc	60 °C	70 °C	75 °C	x
			Lifetime	> 100,000 h	80,000 h	60,000 h	x
PCIS 150 outdoor FOX B011	HI/HS	1x150 W	tc	60 °C	70 °C	75 °C	x
			Lifetime	> 100,000 h	80,000 h	60,000 h	x

### Additional information

Additional technical information at  
[www.tridonic.com](http://www.tridonic.com) → Technical Data

Guarantee conditions at  
[www.tridonic.com](http://www.tridonic.com) → Services

No warranty if device was opened.