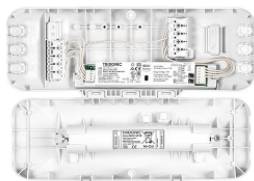

EM converterPACK BASIC NiCd/LiFePO4 50 V

BASIC version

**Product description**

- _ Remote pack for luminaire conversion
- _ Pre wired EM converterLED and battery contained
- _ Please note that due to EU law, this article is available for purchasing only outside of the European Union.
- _ For LED modules with a forward voltage of 10 – 54 V
- _ SELV for output voltage < 60 V DC
- _ Ideal for ceiling openings of diameter ≥ 150 mm and for mounting depths ≥ 100 mm
- _ EM = Emergency
- _ Nominal lifetime up to 100,000 h
- _ 5 years guarantee (conditions at <https://www.tridonic.com/manufacture-guarantee-conditions>)

Properties

- _ Non maintained operation
- _ 3 h rated duration
- _ Compatible with all dimmable and non-dimmable constant current LED driver (see data sheet, LED driver compatibility)
- _ 3-pole technology: 2-pole LED module changeover and delayed power switching for the LED driver
- _ Automatic shutdown of output if LED load is out of range
- _ Constant output voltage
- _ Electronic charge system
- _ Deep discharge protection
- _ Short-circuit-proof battery connection
- _ Strain relief and terminals included

Batteries

- _ High-temperature cells
- _ NiCd or LiFePO4 batteries
- _ 4 year design life for NiCd batteries
- _ 2 years guarantee for NiCd batteries (conditions at <https://www.tridonic.com/manufacture-guarantee-conditions>)
- _ 4 – 8 years design life for LiFePO4 batteries
- _ 5 years guarantee for LiFePO4 batteries (conditions at <https://www.tridonic.com/manufacture-guarantee-conditions>)

Website

<http://www.tridonic.com/89800706>



EM converterPACK BASIC NiCd/LiFePO4 50 V

BASIC version

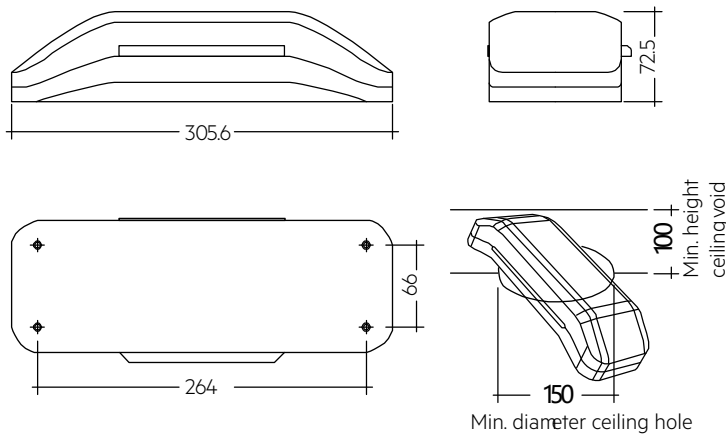
**Ordering data**

Type	Article number	Rated duration	Number of cells	Packaging, carton	Packaging, pallet	Weight per pc.	Dimensions L x W x H
EM converterPACK BASIC 233 NiCd 50V	89800706	3 h	3	1 pc(s).	126 pc(s).	0.81 kg	305.6 x 115.3 x 72.5 mm
EM converterPACK BASIC 232A LiFePO4 50V	89800707	3 h	3	1 pc(s).	126 pc(s).	0.57 kg	305.6 x 115.3 x 72.5 mm

Technical data

Rated supply voltage	220 – 240 V
Mains frequency	50 / 60 Hz
Forward voltage range LED module	10 – 54 V
Output current	Refer to EM converterLED BASIC data sheet
Starting time	< 0.25 s from detection of emergency event
Overvoltage protection	320 V (for 48 h)
U-OUT (including open- / short-circuit and double load)	60 V
Max. open circuit voltage	60 V
Battery charging time	24 h
Ambient temperature t_a	5 ... +45 °C
Max. casing temperature t_c	75 °C
Mains voltage changeover threshold	According to EN 60598-2-22
Mains surge capability (between L - N)	1 kV
Mains surge capability (between L/N - PE)	2 kV
Type of protection	IP20
Lifetime	up to 100,000 h
Guarantee (conditions at www.tridonic.com)	5 Year(s)
Dimensions L x W x H	305.6 x 115.3 x 72.5 mm

Status indication green LED EM CON

Accessory



Product description

- _ A green LED indicates that charging current is flowing into the battery
- _ 0.3 / 1.0 m cable length
- _ Plug connection

Website

<http://www.tridonic.com/89800269>



Ordering data

Type	Article number	Packaging, bag	Packaging, carton	Weight per pc.
LED EM green, 1.0 m CON	89800269	25 pc(s).	200 pc(s).	0.015 kg
LED EM green, HO 1.0 m CON	89800271	25 pc(s).	200 pc(s).	0.015 kg
LED EM green, 0.6 m CON	89800472	25 pc(s).	200 pc(s).	0.009 kg
LED EM green, HO 0.6 m CON	89800473	25 pc(s).	200 pc(s).	0.009 kg
LED EM green, 0.3 m CON	89800270	25 pc(s).	200 pc(s).	0.005 kg
LED EM green, HO 0.3 m CON	89800272	25 pc(s).	200 pc(s).	0.005 kg

Test switch EM3

Accessory



Product description

- _ For connection to the emergency lighting unit
- _ For checking the device function
- _ Plug connection
- _ Dielectric strength: 1,500 V AC for 60 seconds

Website

<http://www.tridonic.com/89899956>



Ordering data

Type	Article number	Packaging, bag	Packaging, carton	Weight per pc.
Test switch EM 3	89899956	25 pc(s).	200 pc(s).	0.01 kg

Approval marks

RoHS

ACD EM LED INDICATOR HOLDER

Accessory



Product description

- _ Holder for indicator LED in emergency operation
- _ Glow-wire test with a temperature of 850 °C passed

Website

<http://www.tridonic.com/28002189>

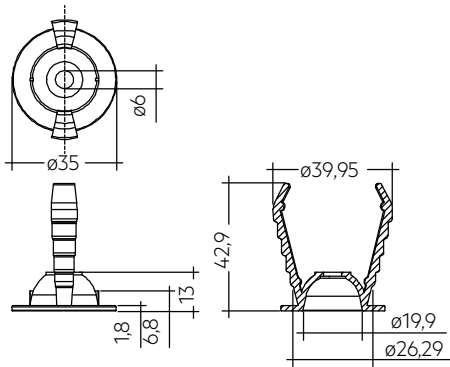

Ordering data

Type	Article number	Colour	Packaging, carton	Weight per pc.
ACD EM LED INDICATOR HOLDER	28002189	White	120 pc(s).	0.006 kg