

EM ready2apply BASIC 1 – 2 W

EM ready2apply

Product description

- LED emergency module suitable for direct installation in ceilings
- Complete set with integrated electronics, LED module, heat sink, optics and battery
- Includes click-in multi-lens option for anti-panic, escape route and spot illumination
- Emergency lighting function for manual testing
- Small size ceiling hole, 40 – 43 mm diameter, 80 mm height

Properties

- Output power 0.75 – 1.50 W
- Very low stand-by power loss
- Maintained and non-maintained variants
- 1 or 3 h rated duration (separate variants)
- Plug-in Lithium Iron Phosphate Battery with strain-relief
- 5 years guarantee electronic (LED Driver)
- 3 years guarantee battery



Standards, page 4

Wiring diagrams and installation examples, page 4





EM ready2apply BASIC 1 – 2 W

EM ready2apply

Technical data

Rated supply voltage AC	220 – 240 V
Input voltage range AC (tolerance for safety)	198 – 264 V
Input voltage range AC (tolerance for performance)	198 – 254 V
Mains frequency	50 / 60 Hz
Overvoltage protection	320 V (for 48 h)
Time to light (emergency operation)	< 0.5 s from detection of emergency event
THD normal operation (maintained operation, at 230 V, 50 Hz, charging)	75 %
Output current tolerance	± 5 %
LF current ripple	± 5 %
Ambient temperature t_a	+5 ... +30 °C
Mains voltage changeover threshold	According to EN 60598-2-22
Type of protection	IP20
Impact protection rating ^①	IK03
Protection class	II
Colour temperature	6,500 K
Colour tolerance	Mac Adams 3
Colour rendering index CRI	> 80
Nominal life-time	50,000 h
EoF_1	1

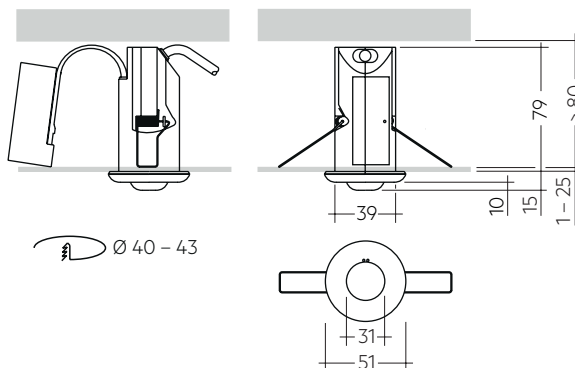

Ordering data

Type	Article number	Operating mode	Rated duration	Number of cells	Packaging carton	Packaging pallet	Weight per pc.
EM R2A BASIC NM 111 2W	89800534	Non-maintained	1 h	1	1 pc(s).	380 pc(s).	0.18 kg
EM R2A BASIC M 111 2W	89800535	Maintained	1 h	1	1 pc(s).	380 pc(s).	0.19 kg
EM R2A BASIC NM 131 1W	89800533	Non-maintained	3 h	1	1 pc(s).	380 pc(s).	0.18 kg
EM R2A BASIC NM 132 2W	89800536	Non-maintained	3 h	2	1 pc(s).	380 pc(s).	0.22 kg
EM R2A BASIC M 132 2W	89800537	Maintained	3 h	2	1 pc(s).	380 pc(s).	0.23 kg

Specific technical data

Type	Number of battery cells	Rated duration	Mains current (230 V, 50 Hz), maintained		Mains current (230 V, 50 Hz), non-maintained		Mains power (230 V, 50 Hz), maintained		Mains power (230 V, 50 Hz), non-maintained		Typ. λ (at 230 V, 50 Hz, charging)	Typ. output current	Typ. forward voltage	Output power
			Charging	Charger off	Charging	Charger off	Charging	Charger off	Charging	Charger off				
Normal operation														
EM R2A BASIC NM 111 2W	1	1 h	–	–	10 mA	5 mA	–	–	1.5 W	0.6 W	0.63c	–	–	–
EM R2A BASIC M 111 2W	1	1 h	35 mA	26 mA	–	–	4.5 W	3.2 W	–	–	0.58c	126 mA	12 V	1.50 W
EM R2A BASIC NM 131 1W	1	3 h	–	–	10 mA	5 mA	–	–	1.5 W	0.6 W	0.63c	–	–	–
EM R2A BASIC NM 132 2W	2	3 h	–	–	16 mA	5 mA	–	–	2.5 W	0.6 W	0.63c	–	–	–
EM R2A BASIC M 132 2W	2	3 h	40 mA	26 mA	–	–	5.5 W	3.2 W	–	–	0.58c	126 mA	12 V	1.50 W
Emergency operation														
EM R2A BASIC NM 111 2W	1	1 h	–	–	–	–	–	–	–	–	–	126 mA	12 V	1.50 W
EM R2A BASIC M 111 2W	1	1 h	–	–	–	–	–	–	–	–	–	126 mA	12 V	1.50 W
EM R2A BASIC NM 131 1W	1	3 h	–	–	–	–	–	–	–	–	–	64 mA	11.3 V	0.75 W
EM R2A BASIC NM 132 2W	2	3 h	–	–	–	–	–	–	–	–	–	126 mA	12 V	1.50 W
EM R2A BASIC M 132 2W	2	3 h	–	–	–	–	–	–	–	–	–	126 mA	12 V	1.50 W

^① IK rating valid for lens

Product description

- Lithium Iron Phosphate replacement battery pack for use with EM ready2apply emergency lighting units
- 8-year design life (at up to 30 °C ambient)
- 3-year guarantee

Properties

- Certified quality manufacturer
- Casing material made of polycarbonate
- Charge efficiency > 90 %
- Low self discharge
- Compact micro USB type B connector providing polarity safe battery connection
- Protection and monitoring circuit built into battery enclosure
- Deep discharge protection
- Suitable for emergency lighting equipment as per IEC 60598-2-22

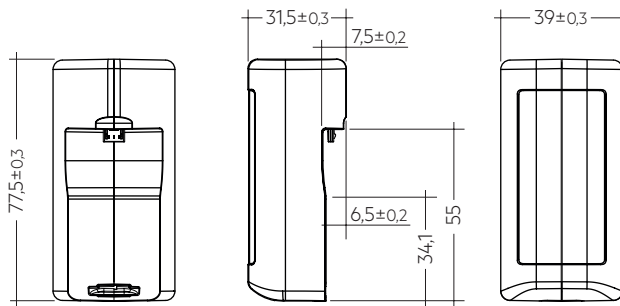

Ordering data

Type	Article number	Packaging, carton	Weight per pc.
Battery pack 1.5 Ah			
PACK-LiFePO4 1,5Ah R2A	89800555	1 pc(s).	0.062 kg
Battery pack 3.0 Ah			
PACK-LiFePO4 3,0Ah R2A	89800556	1 pc(s).	0.104 kg

1. Standards

acc. to EN 50172
EN 55015
EN 60068-2-29
EN 60068-2-30
EN 60068-2-64
EN 60598-1
EN 60598-2-2
EN 60598-2-22
EN 61000-3-2
EN 61347-1
EN 61347-7
EN 61347-2-13
EN 61547
EN 62384
IEC 62133 (related to Lithium Iron battery)
UN 38.3 (related to Lithium Iron battery)
EN 62031
EN 62471

1.1 Glow-wire test

according to EN 60598-1 with increased temperature of 850 °C passed.

2. Thermal data

2.1 Temperature range

According to the standard IEC 60598-1 a LED Driver for remote installation has a max. case temperature of 90 °C. The ambient temperature range t_a for the EM R2A BASIC is defined to meet this requirement.

2.2 Expected life-time

2.2.1 Electronics

Average life-time 50,000 hours under rated conditions with a failure rate of less than 10 %. Average failure rate of 0.2 % per 1000 operating hours.

Expected life-time

Type	t_a	25 °C	30 °C
EM R2A BASIC	life-time	> 50,000 h	50,000 h

2.2.2 Life-time, lumen maintenance and failure rate for LED module

The light output of an LED module decreases over the life-time, this is characterized with the L value.

L70 means that the LED module will give 70 % of its initial luminous flux. This value is always related to the number of operation hours and therefore defines the life-time of an LED module.

As the L value is a statistical value the lumen maintenance may vary over the delivered LED modules.

The B value defines the amount of modules which are below the specific L value, e.g. L70B10 means 10 % of the LED modules are below 70 % of the initial luminous flux, respectively 90 % will be above 70 % of the initial value.

Life-time declarations are informative and represent no warranty claim.

t_a temperature	L90 / B50	L80 / B50	L70 / B10
25 °C	50,000 h	-	50,000 h
30 °C	-	50,000 h	-

2.3 Storage conditions

- Humidity: 45 % up to max. 85 %, not condensed (max. 56 days/year at 85 %)
- Storage time / temperature: max. 6 months at -20 °C up to +45 °C (< 3 months at +45 °C)

Note: The devices have to be within the specified temperature range (t_a) before they are operated.

3. Installation / Wiring

3.1 Lens assembly

- Wear gloves when mounting the lens
- Take care of the mounting direction of the escape route lens
- Use screwdriver for replacing/removing lens
 - + 2. Push lens clips with screwdriver via openings on both sides
 3. Remove lens

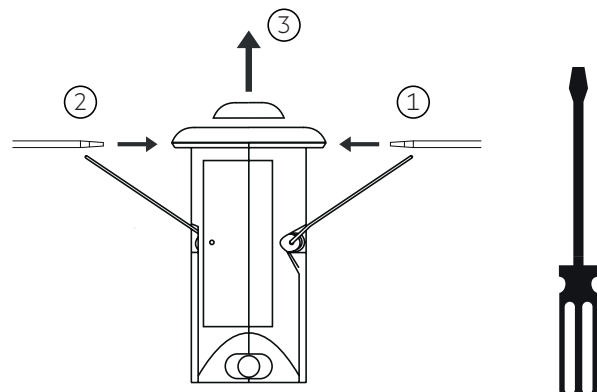

3.2 Wiring diagrams

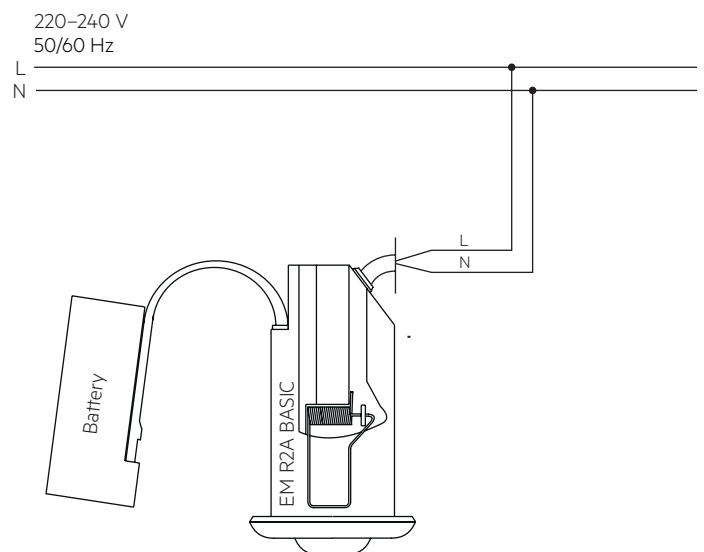

Note: Battery must be connected before mains connection.

3.3 Wiring type and cross-section

Wiring

Mains (N, L): brown, blue

Cable length: 250mm with strain relief at the R2A BASIC module

Cable: low smoke, halogen free

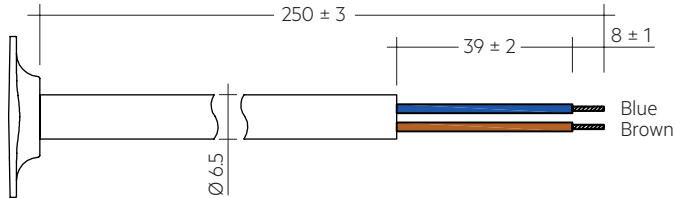
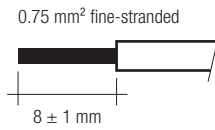

Recommended connector with strain-relief (plug and socket): to be defined

Only a terminal complying with EN 60998-2-1 or EN 60998-2-2 shall be used

Note: If mains cable or battery strap are damaged the luminaire must be disposed.

4. Mechanical data

4.1 Housing properties

- Polycarbonate white RAL 9016

4.2 Battery connection

Battery pack end termination

Compact micro USB type B connector providing safe battery connection

Module end termination

- Battery strap with compact micro USB type B connector
- Strain relief at the module casing and locking clip for secure connection of the battery pack
- Battery strap: low smoke, halogen free

Note: Strap not suitable for connection of any other micro USB device other than the ready2apply battery pack

4.3 Fixing

Spring fixing through hole in ceiling

- Hole diameter: 40 – 43 mm
- Ceiling thickness: 1 – 25 mm
- Ceiling void height: > 80 mm

5. Electrical data

5.1 Maximum loading of automatic circuit breakers

Automatic circuit breaker type	C10	C13	C16	C20	B10	B13	B16	B20	Inrush current	
Installation Ø	1.5 mm ²	1.5 mm ²	2.5 mm ²	4 mm ²	1.5 mm ²	1.5 mm ²	2.5 mm ²	4 mm ²	I_{max}	time
EM R2A BASIC	180	260	260	260	90	130	130	130	10 A	120 µs

5.2 Harmonic distortion in the mains supply (at 230 V / 50 Hz and 2-cell maintained charging) in %

	THD	3.	5.	7.	9.	11.
EM R2A BASIC	< 75	< 62	< 33	< 19	< 18	< 13

5.3 Battery charge / discharge

EM R2A BASIC 1 – 2 W, 1 / 3 h

Type		EM R2A BASIC 2 W	EM R2A BASIC 2 W	EM R2A BASIC 1 W
Article no.		89800534 / 89800535	89800536 / 89800537	89800533
Cells		1 cells	2 cells	1 cells
Duration		1 h	3 h	3 h
Battery charge time	Initial	20 h		
	Recharge	12 h		
	Trickle charge	continuously and battery voltage controlled		
Typ. charge current [®]	Initial charge	140 mA	290 mA	140 mA
	Recharge	140 mA	290 mA	140 mA
	Trickle charge	140 mA / 0 mA	290 mA / 0 mA	140 mA / 0 mA
Mains power consumption	Initial charge	< 1.095 W	< 1.095 W	< 1.095 W
	Recharge	< 1.095 W	< 1.095 W	< 1.095 W
	Trickle charge	< 1.095 W / 0 W	< 1.095 W / 0 W	< 1.095 W / 0 W
Discharge current at 3.2 V (nominal)		625 mA	625 mA	320 mA

[®] Automatic recharge when battery voltage falls below 3.4 V. Charger off (0 mA) when battery voltage exceeds 3.6 V.

Note: Battery protected against operation at excessive temperatures (charging stopped when battery cell temperature < 0 °C or > 60 °C)

5.4 Battery selection for replacement

EM R2A BASIC 1 – 2 W, 1 / 3 h

		Type	EM R2A BASIC 2 W	EM R2A BASIC 2 W	EM R2A BASIC 1 W
Article no.			89800534 / 89800535	89800536 / 89800537	89800533
Cells			1 cells	2 cells	1 cells
Duration			1 h	3 h	3 h
Technology and capacity	Design	Number of cells	Type	Article no.	Assignable batteries
Lithium Iron Phosphate 1.5 Ah	single cell	1	PACK-LiFePO4 1,5Ah R2A	89800555	•
Lithium Iron Phosphate 3 Ah	side by side	1 + 1	PACK-LiFePO4 3,0Ah R2A	89800556	•

Note: If the rated duration of operation cannot be reached the battery must be replaced. Remove mains during battery replacement.

6. Functions

6.1 Status indication

The indication LED is integrated in the bezel. A green LED indicates that charging current is flowing into the battery.

The battery is protected against operation at excessive temperatures (charging stops and indication LED turns off when battery cell temperature < 0 °C or > 60 °C).

6.2 Test switch

Test switch is integrated in the bezel. This can be used to execute function test as long as the switch pressed > 1 s

To initiate a test use a suitable tool, refer to drawing below.

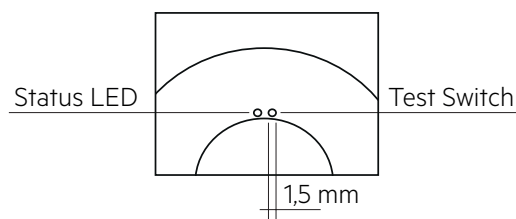

6.3 Technical data batteries

Accu Lithium Iron Phosphate

Case temperature range
to ensure 8 years design life

1.5 / 3.0 Ah	+5 °C to +30 °C
Battery voltage/cell	3.2 V
Single cell dimensions	
Diameter	18 mm
Height	65 mm
Capacity one cell	1.5 Ah
Capacity two cell pack	3.0 Ah
Max. short term temperature (reduced life-time)	55 °C
Max. number discharge cycles	50 cycles total
Packing quantity	1 pc. per carton

Comply with UN 38.3 and IEC 62133 (safety testing) protected against over charge, over discharge, charging at excessive temperatures, short-circuit and over current.

For battery data see separate data sheet.

7. Optical properties

7.1 Anti panic

EM R2A BASIC 1W – Max. spacing for >0.5 lux^①

Height	Centre to end ^②		Centre to centre ^③	
	Trans	Axial	Trans	Axial
2.5 m	2.85 m	2.80 m	9.40 m	9.40 m
3.0 m	2.75 m	2.80 m	10.40 m	10.40 m
3.5 m	2.70 m	2.70 m	10.95 m	10.95 m
4.0 m	2.50 m	2.50 m	11.30 m	11.25 m
5.0 m	0.40 m	0.40 m	11.25 m	11.25 m

All values for $t_a = 30\text{ °C}$

Luminous flux: 121 lm

^① Maintenance factor = 0.8, photometric data available on request

^② Distance between module and wall

^③ Distance between two modules

EM R2A BASIC 2W – Max. spacing for >0.5 lux^①

Height	Centre to end ^②		Centre to centre ^③	
	Trans	Axial	Trans	Axial
2.5 m	3.85 m	3.80 m	10.90 m	10.85 m
3.0 m	3.80 m	3.75 m	11.90 m	11.90 m
3.5 m	3.80 m	3.80 m	12.90 m	12.90 m
4.0 m	3.70 m	3.70 m	13.90 m	13.85 m
5.0 m	3.55 m	3.50 m	14.90 m	14.90 m
6.0 m	3.10 m	3.05 m	15.10 m	15.05 m

All values for $t_a = 30\text{ °C}$

Luminous flux: 200 lm

^① Maintenance factor = 0.8, photometric data available on request

^② Distance between module and wall

^③ Distance between two modules

Light distribution

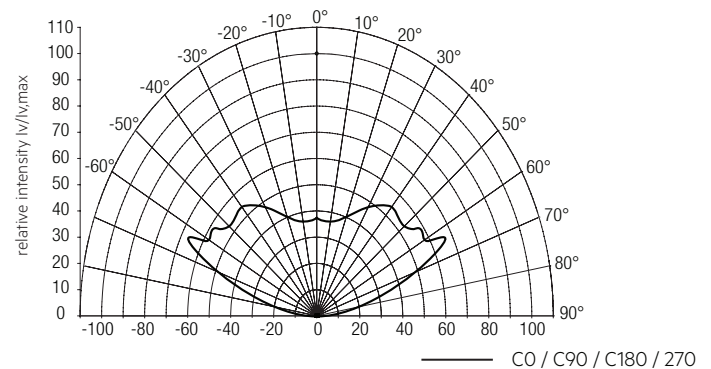

7.2 Escape route

EM R2A BASIC 1W – Max. spacing for >1.0 lux^①

Height	Centre to end ^②		Centre to centre ^③	
	Trans	Axial	Trans	Axial
2.5 m	3.70 m	1.10 m	9.95 m	5.70 m
3.0 m	3.90 m	1.20 m	10.20 m	4.85 m
3.5 m	4.05 m	1.30 m	10.55 m	4.80 m
4.0 m	4.20 m	1.40 m	10.95 m	3.40 m
5.0 m	4.30 m	1.45 m	11.60 m	3.80 m
6.0 m	4.25 m	1.40 m	12.05 m	4.00 m
7.0 m	3.95 m	1.20 m	12.20 m	4.10 m
8.0 m	3.20 m	0.90 m	12.15 m	4.05 m

All values for $t_a = 30^\circ\text{C}$

Luminous flux: 117 lm

^① Maintenance factor = 0.8, photometric data available on request

^② Distance between module and wall

^③ Distance between two modules

EM R2A BASIC 2W – Max. spacing for >1.0 lux^①

Height	Centre to end ^②		Centre to centre ^③	
	Trans	Axial	Trans	Axial
2.5 m	4.75 m	2.75 m	11.65 m	6.55 m
3.0 m	4.80 m	2.95 m	12.75 m	7.20 m
3.5 m	5.05 m	1.50 m	13.45 m	6.85 m
4.0 m	5.20 m	1.65 m	13.60 m	6.50 m
5.0 m	5.50 m	1.80 m	14.30 m	4.35 m
6.0 m	5.70 m	1.90 m	15.05 m	4.85 m
7.0 m	5.75 m	1.90 m	15.60 m	5.15 m
8.0 m	5.65 m	1.85 m	16.05 m	5.35 m

All values for $t_a = 30^\circ\text{C}$

Luminous flux: 200 lm

^① Maintenance factor = 0.8, photometric data available on request

^② Distance between module and wall

^③ Distance between two modules

Light distribution

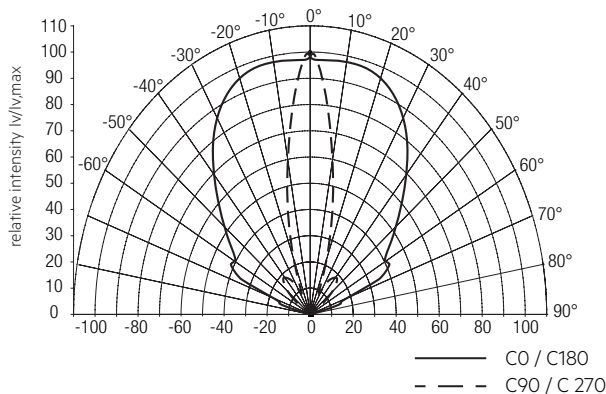

7.3 Spot

EM R2A BASIC 1W – Max. spacing for >0.5 lux / > 5 lux^①

Minimum illuminance	Height	Centre to end ^②		Centre to centre ^③	
		Trans	Axial	Trans	Axial
0.5	2.5 m	1.05 m	1.90 m	4.50 m	4.30 m
	3.0 m	1.30 m	1.25 m	5.35 m	5.20 m
	3.5 m	1.50 m	1.45 m	6.25 m	6.05 m
	4.0 m	1.60 m	1.60 m	6.85 m	6.05 m
	5.0 m	1.80 m	1.80 m	6.00 m	5.95 m
	6.0 m	2.00 m	1.95 m	5.85 m	5.80 m
	7.0 m	2.10 m	2.05 m	6.00 m	6.00 m
	8.0 m	2.15 m	2.10 m	6.40 m	6.35 m
5.0	2.5 m	0.70 m	0.65 m	2.00 m	2.00 m
	3.0 m	0.70 m	0.65 m	2.20 m	2.20 m
	3.5 m	0.70 m	0.70 m	2.40 m	2.35 m
	4.0 m	0.70 m	0.70 m	2.50 m	2.50 m
	5.0 m	0.70 m	0.65 m	2.65 m	2.65 m
	6.0 m	0.60 m	0.55 m	2.70 m	2.65 m
	7.0 m	0.35 m	0.30 m	2.75 m	2.70 m

All values for $t_a = 30^\circ\text{C}$

Luminous flux: 115 lm

^① Maintenance factor = 0.8, photometric data available on request

^② Distance between module and wall

^③ Distance between two modules

EM R2A BASIC 2W – Max. spacing for >0.5 lux / > 5 lux^①

Minimum illuminance	Height	Centre to end ^②		Centre to centre ^③	
		Trans	Axial	Trans	Axial
0.5	2.5 m	1.05 m	1.90 m	8.40 m	4.30 m
	3.0 m	2.35 m	1.25 m	5.35 m	5.20 m
	3.5 m	2.80 m	1.45 m	6.25 m	6.05 m
	4.0 m	1.70 m	1.70 m	7.90 m	5.85 m
	5.0 m	2.10 m	2.05 m	8.90 m	8.40 m
	6.0 m	2.30 m	2.30 m	8.15 m	8.10 m
	7.0 m	2.50 m	2.45 m	8.00 m	8.00 m
	8.0 m	2.65 m	2.60 m	7.80 m	7.85 m
5.0	2.5 m	0.85 m	0.80 m	2.50 m	2.45 m
	3.0 m	0.90 m	0.85 m	2.55 m	2.55 m
	3.5 m	0.90 m	0.90 m	2.75 m	2.75 m
	4.0 m	0.90 m	0.95 m	2.95 m	2.95 m
	5.0 m	0.95 m	0.90 m	3.30 m	3.25 m
	6.0 m	0.95 m	0.90 m	3.50 m	3.45 m
	7.0 m	0.85 m	0.85 m	3.60 m	3.55 m
	8.0 m	0.75 m	0.75 m	3.60 m	3.60 m

All values for $t_a = 30^\circ\text{C}$

Luminous flux: 200 lm

^① Maintenance factor = 0.8, photometric data available on request

^② Distance between module and wall

^③ Distance between two modules

Light distribution

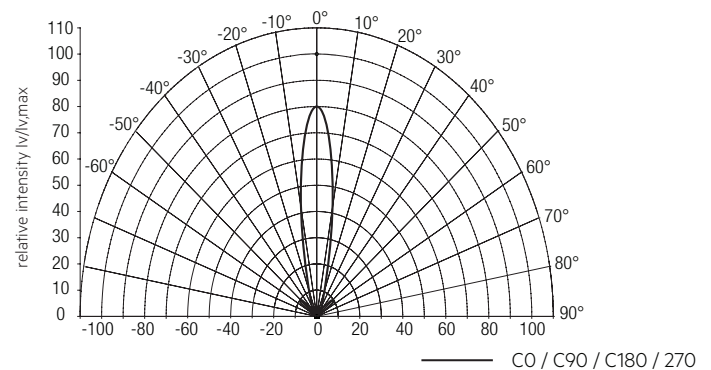

8. Miscellaneous

8.1 Black Box data recording

Recording of several parameters only accessible for Tridonic.

8.2 Additional information

Additional technical information at www.tridonic.com → Technical Data

Guarantee conditions at www.tridonic.com → Services

The light source of this luminaire is not replaceable; when the light source reaches its end of life replace the whole luminaire. Life-time declarations are informative and represent no warranty claim. No warranty if device was opened.