

Non-maintained emergency lighting LED Driver for manual testing for LED modules with a forward voltage of 10 to 200 V for luminaire installation  
3 h rated duration

## EM converterLED BASIC Installation and wiring instructions

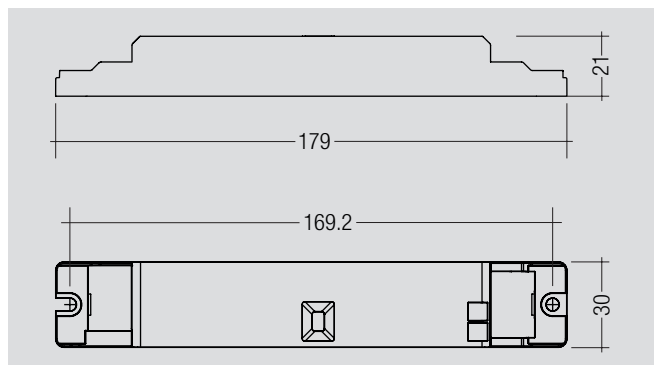

### Description

EM converterLED BASIC is designed for use in emergency luminaires in conjunction with LED modules and LED Drivers from Tridonic and other manufacturers. It is compatible with LED light modules for linear / area as well as downlight applications and can be used with normal fixed output or dimming LED Drivers of up to 150 W power.

These modules are approved to IEC / EN 61347-2-7 and provide a battery charge current that is within the range of charge currents quoted on the Battery Manufacturers Declaration Form for the ended battery types. This compatibility allows converted luminaires to comply with the relevant parts of IEC / EN 60598-2-22.

### Technical data

Rated supply voltage	220 – 240 V
Mains current EM converter LED BASIC 104 50 V	35 mA
Mains current EM converter LED BASIC 104 200 V	30 mA
Mains frequency	50 / 60 Hz
Typ. $\lambda$ (at 230 V, 50 Hz)	0.6
Rated duration	3 h
LED module forward voltage range EM converter LED BASIC 104 50 V	10 – 52 V (SELV)
LED module forward voltage range EM converterLED BASIC 104 200V	50 – 200 V (non-SELV)
Output current	see EM converterLED BASIC data sheet
Maximum output voltage EM converter LED BASIC 104 50 V	60 V
Maximum output voltage EM converter LED BASIC 104 200 V	250 V
Battery charging time	20 h
Ambient temperature range $t_a$	-5 ... + 55 °C
Max. casing temperature $t_c$	70 °C
Terminals	0.5 – 1.5 mm <sup>2</sup> pushwire
Weight	78 g
Mounting	M4 Screws

### Ordering data

Type	Article number	Packaging carton	Packaging Pallet	Weight per pc.
EM converterLED BASIC 50V KIT	89800401	25 pc(s).	300 pc(s).	0.697 kg
EM converterLED BASIC 200V KIT	89800402	25 pc(s).	300 pc(s).	0.697 kg

### Charge status indication LED (included)

Type	Article number
LED EM green, ultra high brightness 1,0 m	89800271

### Important

These instructions contain important safety information, read and follow them carefully. Tridonic will not accept any responsibility for injury, damage or loss, which may arise as a result of incorrect installation, operation, maintenance or disposal.

ISOLATE SWITCHED AND UNSWITCHED MAINS AND NEGATIVE BATTERY SUPPLY BEFORE INSTALLING OR MAINTAINING – High voltage will be present at LED terminals if the battery is not isolated.

HIGH VOLTAGE INSULATION TESTING UP TO 500 V DC IS ONLY ALLOWED BETWEEN THE LINE AND NEUTRAL CONNECTED TOGETHER AND THE EARTH.

### Note to the installer:

Please ensure this leaflet is made available to the user and/or maintenance engineer together with a test record card.

### Conversion

1. IT IS RECOMMENDED THAT THE CONVERSION OF A LUMINAIRE SHOULD BE CARRIED OUT IN ACCORDANCE WITH ICEL 1004.
2. ENSURE THAT THE MODULE AND ASSOCIATED BATTERY OPERATE WITHIN THEIR TEMPERATURE RATINGS.
3. AFTER CONVERSION OF A LUMINAIRE EXISTING COMPONENTS MUST CONTINUE TO OPERATE BELOW THEIR TEMPERATURE RATING.
4. WIRE THE MODULE AND BATTERY INTO THE LUMINAIRE ACCORDING TO THE WIRING DIAGRAM.
5. CLEARLY IDENTIFY THE NEW UNSWITCHED SUPPLY TO THE CONVERTED LUMINAIRE.
6. CHECK OPERATION OF THE LED CHARGE INDICATOR BY CONNECTING THE UNSWITCHED LINE.
7. CHECK OPERATION OF THE LED IN THE EMERGENCY MODE BY DISCONNECTING THE UNSWITCHED SUPPLY AFTER 15 MINUTES.
8. RELABEL THE LUMINAIRE TO IDENTIFY THE COMPANY RESPONSIBLE FOR THE CONVERSION.
9. FILL IN TEST RECORD CARD IF THE LUMINAIRE IS BEING CONVERTED ON SITE.
10. MARK THE DATE OF COMMISSIONING ON THE BATTERY LABEL.

FAILURE TO DO AS MENTIONED ABOVE WILL INVALIDATE ANY WARRANTY CLAIMS.

### Battery (included)

Type	Article number	Number of cells	Type	Capacity	Case temperature range
<b>NiCd D cells – stick</b>					
Accu-NiCd 4A 50	89800117 <sup>①</sup>	1 x 4	stick	4.0 Ah	+5 °C to +50 °C

<sup>①</sup> For replacements please order 89800085.

Max. short term battery case temperature (reduced life-time) 70 °C

### Emergency Operation

After the switchover to emergency operation the EM converterLED is detecting the total forward voltage of the connected LED modules and automatically adjusts the LED current.

### LED forward voltage

The total forward voltage of all the LED light modules operated in emergency mode is used for the decision which type of EM converterLED should be used.

EM converterLED BASIC 104 50V forward voltage range: 10 – 52 V

EM converterLED BASIC 104 200V forward voltage range: 50 – 200 V

The total forward voltage must be within the forward voltage range of the EM converterLED.

### Total forward voltage of all LED modules

The forward voltage of a single LED module can be found in the data sheet. When calculating the total forward voltage of all LED light modules together, series and parallel circuits must be handled differently:

#### Serial circuit

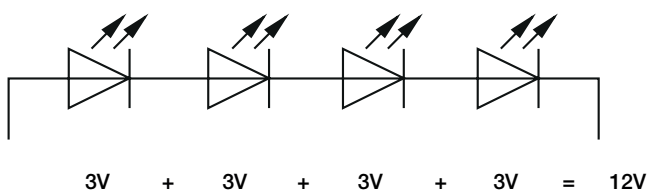

The values of the individual LED modules are summed up.

#### Parallel circuit

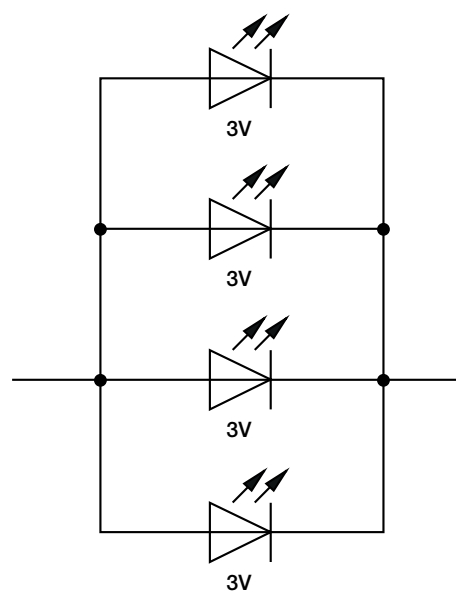

The total value is the same as the value of a single LED module.

### Note:

Parallel circuits make it possible to use multiple LED modules and still be SELV <60V since the forward voltages of the individual modules are not summed up.

### LED Driver compatibility

The EM converterLED emergency unit use 3 pole technology and is compatible with most LED Drivers on the market, however it is important to check that the rating of the LED Driver does not exceed the values specified below:

- The max. allowed output current rating of the associated LED Driver is 2.4 A peak (current rating of switching relays of EM converterLED)
- The max. allowed inrush current rating of the associated LED Driver is 60 A peak for 1 ms (inrush current rating of switching relay of EM converterLED)
- The max. allowed output voltage of the associated LED Driver applied to the EM converterLED output is 450V (voltage withstand between adjacent contact of the single switching relay of the EM converterLED)
- The max. allowed LED load of the associated LED Driver is 150 W in operation. The load must be an LED module.

### Maximum lead length

LED 3 m

Note: The length of LED leads to the LED module must not be exceeded. Note that the length of the EM converterLED leads to the LED module will be added to the length of the leads from the LED Driver to the EM converterLED module when considering the lead length of the LED Driver. Leads should always be kept as short as possible.

### Universal wiring diagram for LED Driver

The following wiring diagrams give a step by step explanation for the conversion of a standard LED luminaire to an LED emergency luminaire.

#### Parallel wiring

##### Step 1:

##### Parallel connection of LED modules

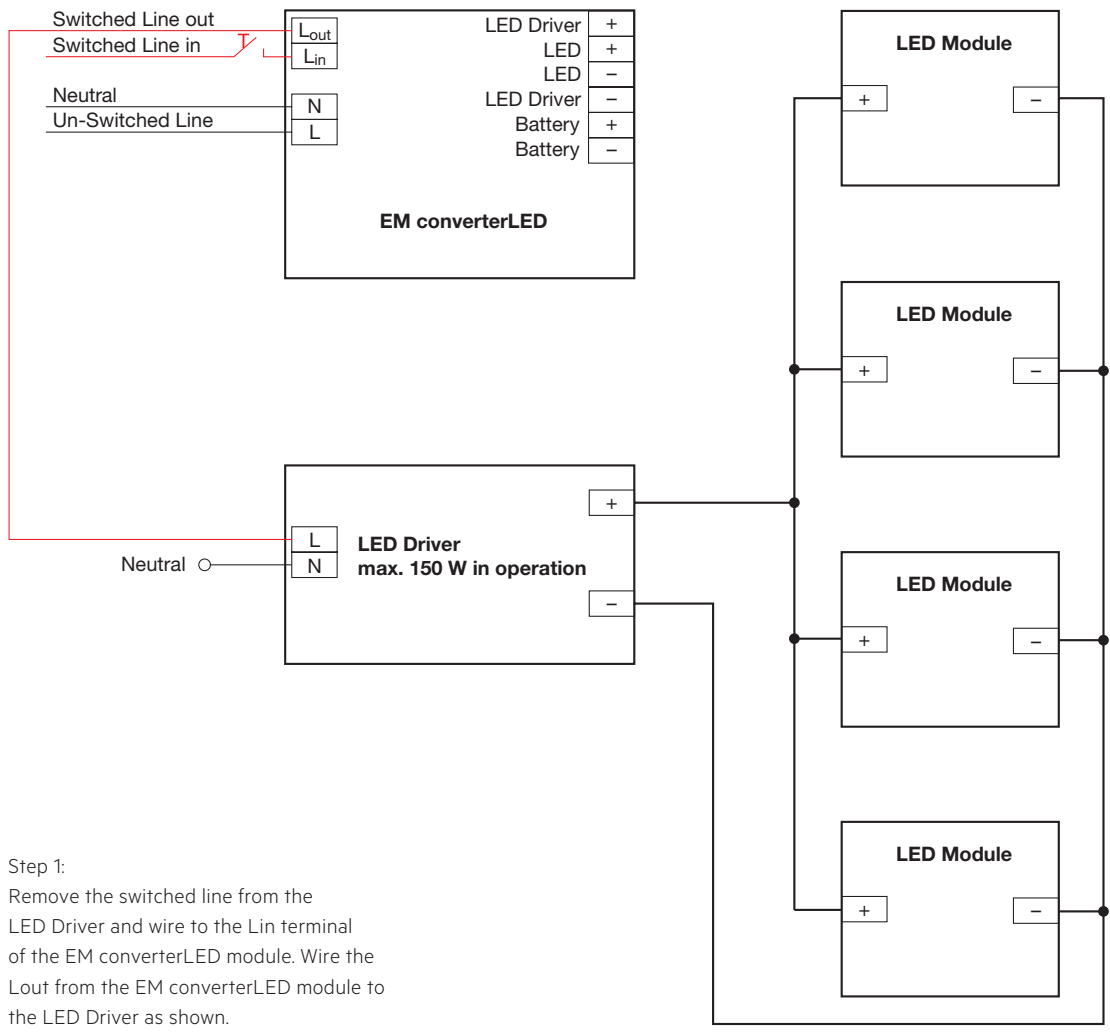

##### Step 1:

Remove the switched line from the LED Driver and wire to the L<sub>in</sub> terminal of the EM converterLED module. Wire the L<sub>out</sub> from the EM converterLED module to the LED Driver as shown.

**Parallel wiring**

**Step 2:**

**Parallel connection of LED modules**

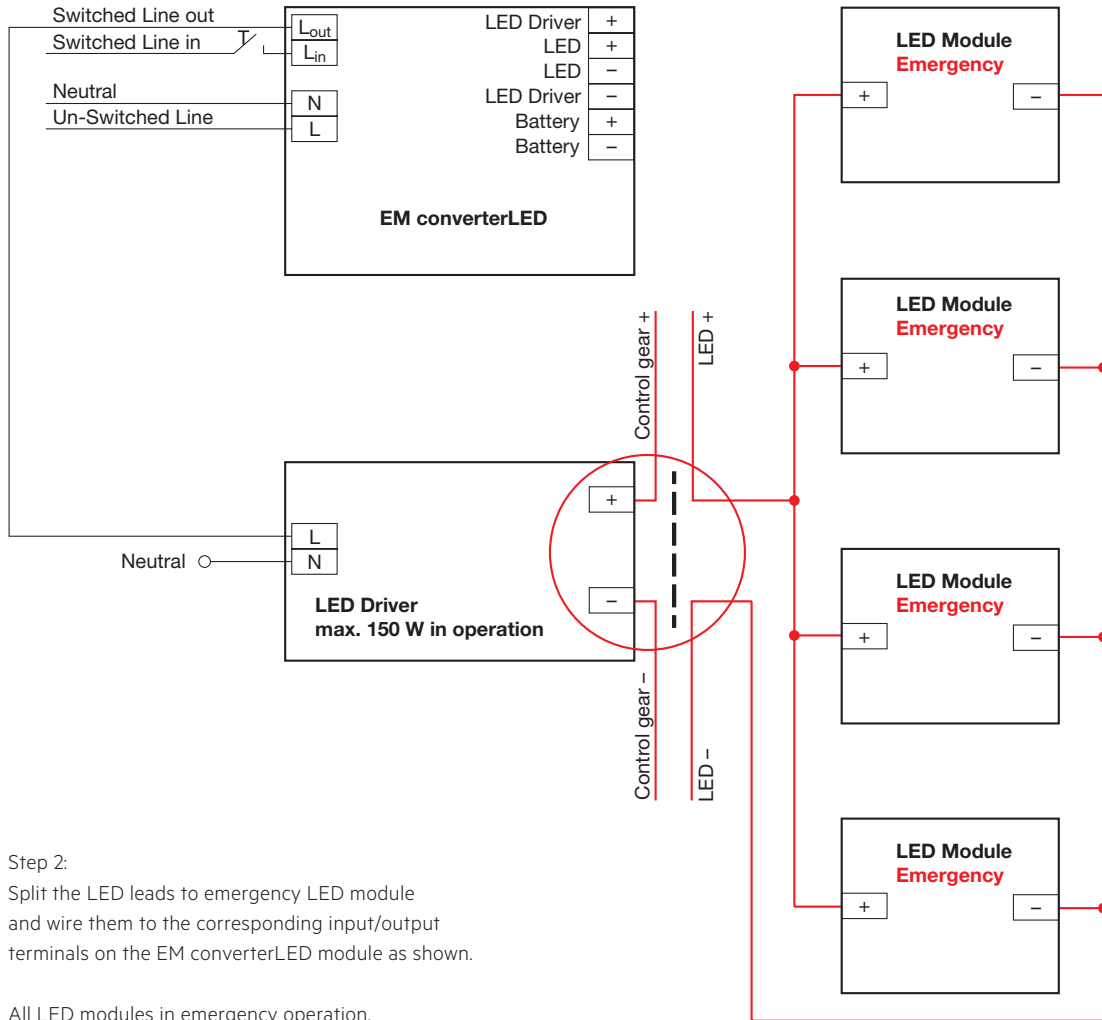

**Step 2:**

Split the LED leads to emergency LED module and wire them to the corresponding input/output terminals on the EM converterLED module as shown.

All LED modules in emergency operation.

**Parallel wiring**

**Step 3:**

**Parallel connection of LED modules**

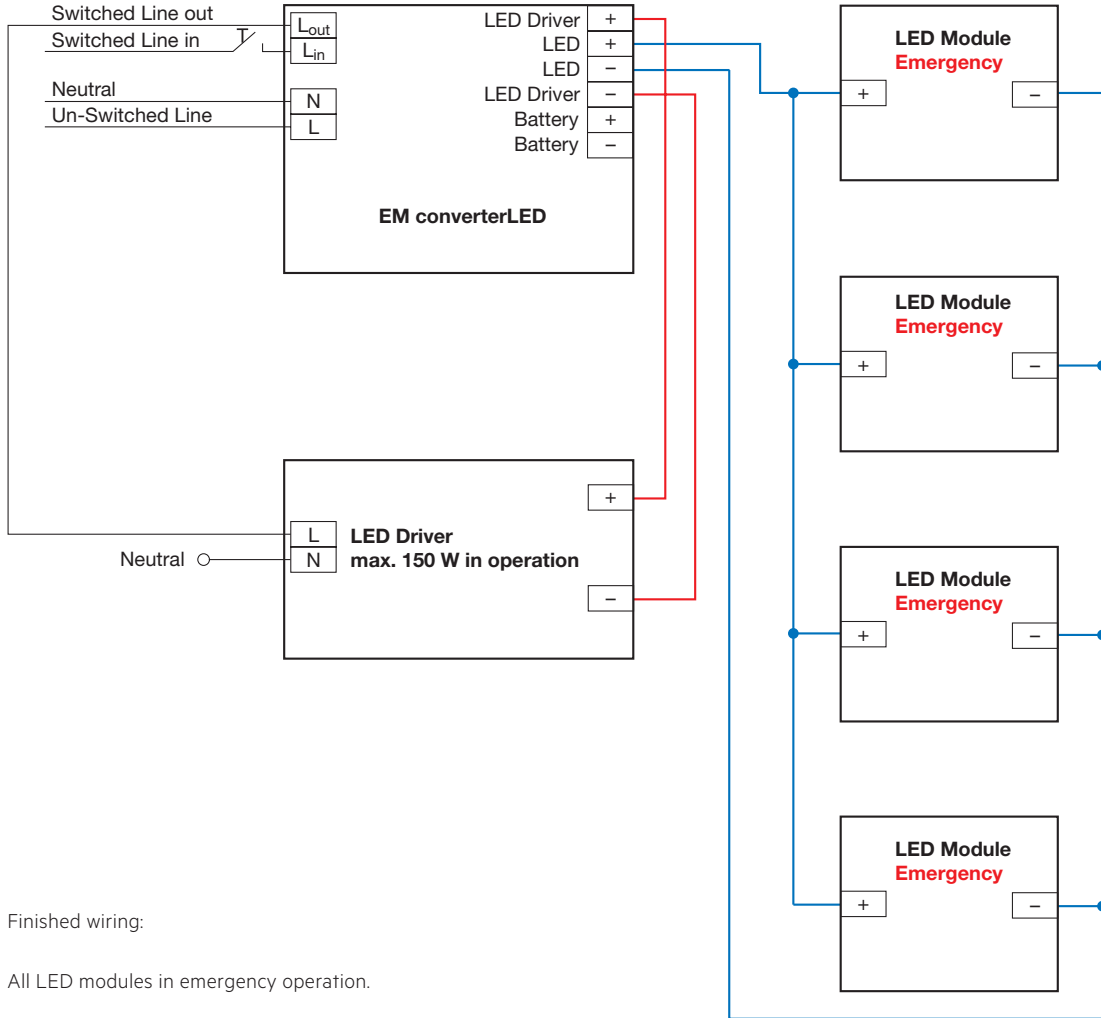

Finished wiring:

All LED modules in emergency operation.

## Serial wiring

### Step 1:

#### Serial connection of LED modules

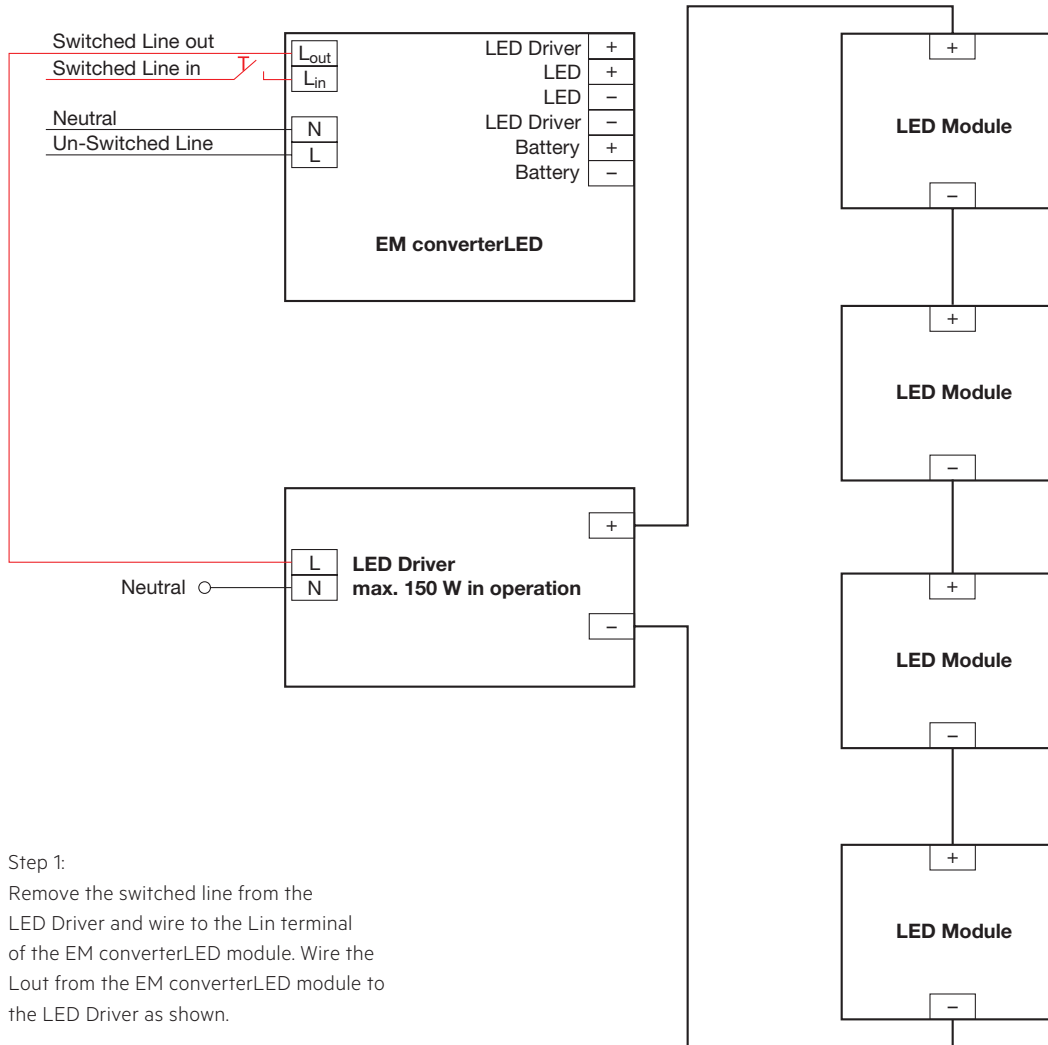

### Step 1:

Remove the switched line from the LED Driver and wire to the Lin terminal of the EM converterLED module. Wire the Lout from the EM converterLED module to the LED Driver as shown.

## Serial wiring

### Step 2:

#### Serial connection of LED modules

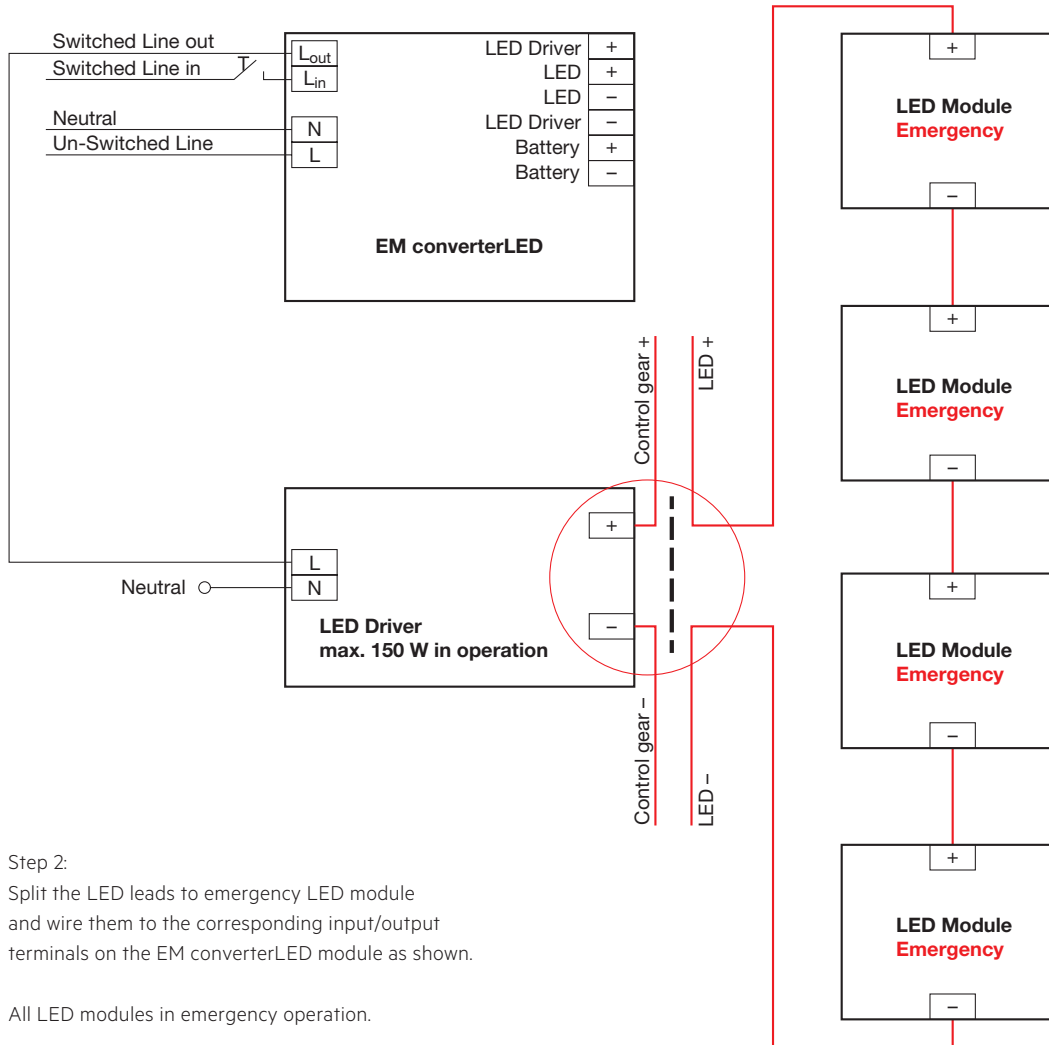

Step 2:

Split the LED leads to emergency LED module and wire them to the corresponding input/output terminals on the EM converterLED module as shown.

All LED modules in emergency operation.



## Serial wiring

### Step 3:

#### Serial connection of LED modules

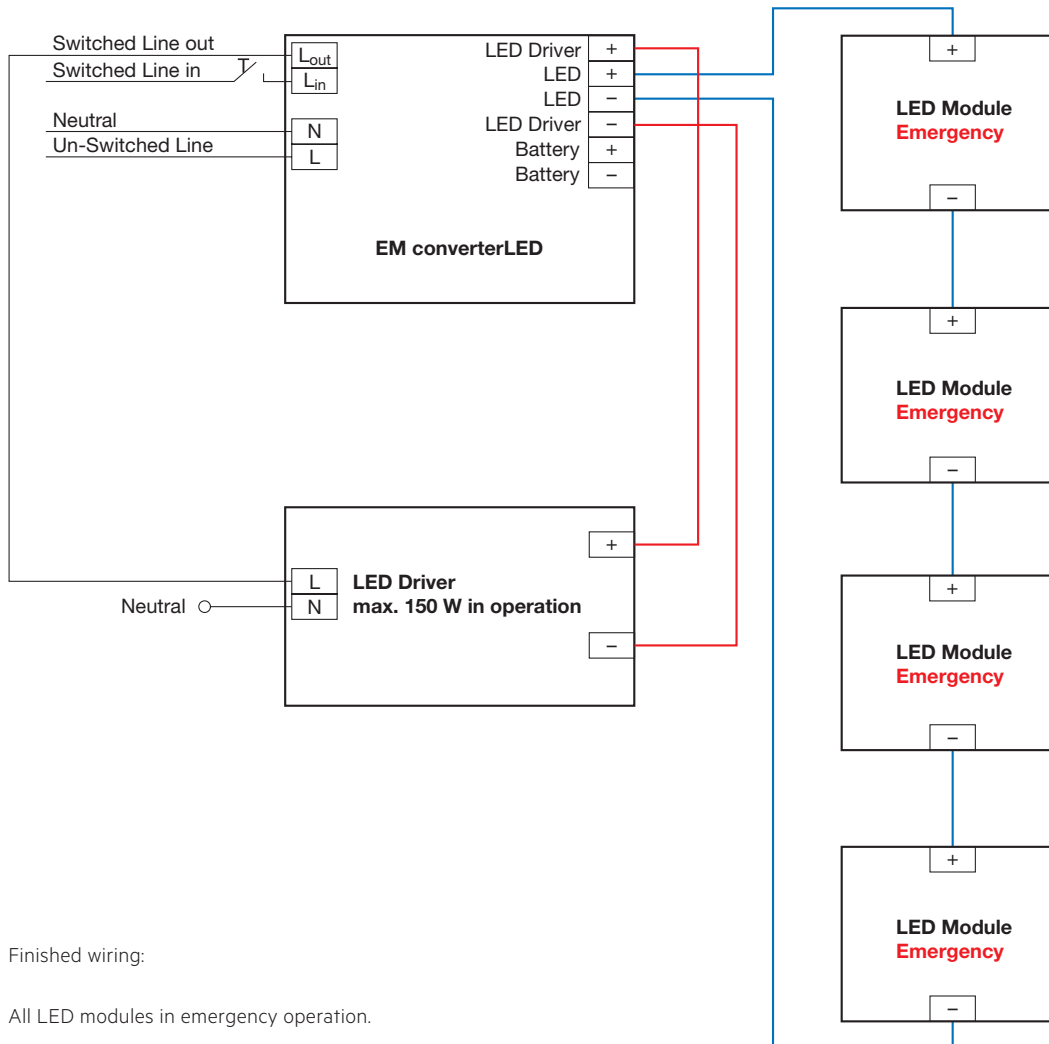

Finished wiring:

All LED modules in emergency operation.

### Wiring guidelines

- EM converterLED BASIC 104 50 V:  
The LED terminals, battery and indicator LED terminals are classified as SELV (output voltage < 60 V DC). Keep the wiring of the input terminals separated from the wiring of the SELV equivalent terminals or consider special wiring (double insulation, 6 mm creepage and clearance) when these connections should be kept SELV.
- The output to the LED is DC but has high frequency content, which should be considered for good EMC compliance.
- LED leads should be separated from the mains connections and wiring for good EMC performance.
- Maximum lead length on the LED terminals is 3 m. For a good EMC performance keep the LED wiring as short as possible.
- Maximum lead length for the Indicator LED connection is 1 m. The test switch and Indicator LED wiring should be separated from the LED leads to prevent noise coupling.
- Battery leads are specified with 0.5 mm cross section and a length of 1.3 m
- To avoid the damage of the control gear, the wiring must be protected against short circuits to earth (sharp edged metal parts, metal cable clips, louver, etc.)

### General notes

#### Safety

This module and associated luminaire has both an unswitched mains electricity supply and a switched supply as well as an internal battery. To ensure safety disconnect all three before installation or maintenance work begins. (Isolate battery by disconnecting the negative lead.)

The nickel cadmium batteries used together with this module contain an electrolyte which can be harmful to eyes and poisonous on open wounds. Care must be taken when handling the batteries, to avoid puncturing the case. If electrolyte comes into contact with skin wash immediately in water.

Batteries must not be subjected to excessive charge or discharge currents. When working with batteries take care not to short circuit them with tools or jewellery etc.

#### Installation

Installation must be carried out by a competent person, in accordance with the national or local wiring regulations and BS 5266 Part 1; Code of Practice for Emergency Lighting. If in any doubt consult a qualified electrician.

Ensure that voltage and frequency requirements are compatible with the available supply.

Observe the correct polarity when making electrical connections.

#### Maintenance

The module does not contain serviceable parts and should not be opened. DOING SO WILL INVALIDATE THE WARRANTY.

To ensure that a luminaire containing LED emergency units complies with EN 55015 for radio frequency conducted interference in both normal and emergency mode it is essential to follow good practice in the wiring layout.

Within the luminaire the switched and unswitched 50 Hz supply wiring must be routed as short as possible and be kept as far away as possible from the LED leads. Through wiring may affect the emc performance of the luminaire.

For maintained operation in conjunction with a LED Driver:  
The length of LED leads must not be exceeded. Note the length of the EM converterLED leads to the LED module adds to the length of the leads from the LED Driver to the EM converterLED module when considering the lead length of the LED Driver.

#### Disposal of Batteries

Do not incinerate batteries. Whilst disposing of small quantities is possible with little or no risk, large numbers require expert handling. Consult the relevant Local Authority Health and Safety Officers.

#### User Obligation

Every care is taken by Tridonic, in the design and construction of its products, to ensure that as far as is reasonably practical, the products, when properly used are safe, and without risk to health.

The health and safety at work act, however, imposes upon the users of a Company's products, an obligation to ensure that all personnel involved with the installation, handling, use or disposal of the products are acquainted with the information provided by the Company, and are made fully aware of any precautions that need to be taken.

#### Modification

Do not attempt to modify this product. Any modification will invalidate the safety/approval marks, and may render the product unsafe. Tridonic will not accept responsibility for any modified product, or any injury damage, or loss, which may arise as a result of unauthorised modification.

#### Change of Specification

Tridonic reserve the right to change specifications without prior notification or public announcement.

## Testing

### Test Circuit

To test luminaires converted with this module it is only necessary to provide a method for disconnecting THE UNSWITCHED SUPPLY.

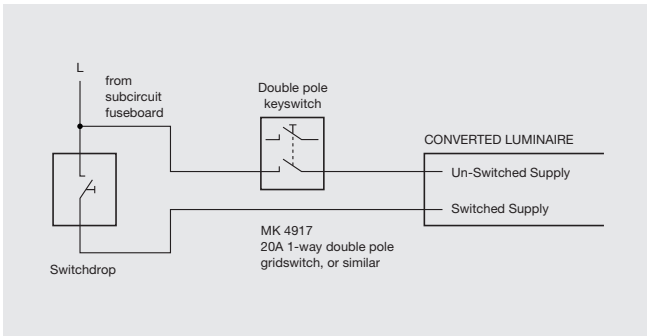

Keyswitch Testing

The unswitched mains supply to this module should be derived from a circuit which is continuously energised. Steps must be taken to ensure that this supply is not inadvertently interrupted at any time. Switches associated with this supply should either be sited in a position inaccessible to unauthorised persons, or be of a tamper proof type.

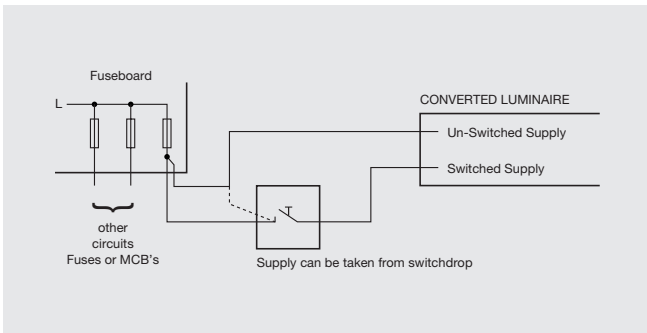

Fuseboard Testing

### Testing

Emergency Lighting must be regularly tested to ensure that it is working and that the batteries achieve the specified duration. Results of testing should be recorded on a test record card. FAILURE TO DO SO WILL INVALIDATE ANY WARRANTY CLAIMS. BS 5266 specifies the following tests.

- **Daily:**

The charge indicator (LED) should be checked to see if it is alight.

- **Monthly:**

To check correct function, the converted luminaire should be energised from its battery for a short period.

To ensure the full functionality is recommended to expand the function test duration to approximately 30 seconds.

- **Yearly:**

The converted luminaire should be energised from its battery for a period of 3 hour duration.

Batteries should be replaced after 4 years or if the luminaire does not meet its rated duration.

Because the failure of the supply could occur immediately after testing, the operational tests above should be carried out at times of least risk. It is important that prior to the tests the unswitched supply must have been connected for at least 24 hours. Test by disconnecting the supply as described in "Test Circuit" which will simulate mains failure.