

IP20 SELV 

Driver LCI 15 W 350/500/700 mA stepDIM Ip BASIC series

Product description

- Constant current LED Driver for luminaire installation
- Implemented stepDIM function
- 10 or 30 % dimming level settable
- Can be used with a standard motion detector (Simple CORRIDOR FUNCTION)
- Nominal life of 50,000 h (at ta max. with a failure rate of max. 0.2 % per 1,000 h)
- 350, 500 or 700 mA output current
- Push-in terminals
- Connecting cable, cable cross-section 0.5 – 1.5 mm²
- Output power 15/16/16.5 W
- SELV
- Type of protection IP20
- Output dimmed analogue (current amplitude)

Properties

- Casing: polycarbonat, white
- Compact dimensions
- Overload protection
- Short-circuit protection
- No-load protection

Technical data

Rated supply voltage	220 – 240 V
AC voltage range	198 – 264 V
DC voltage range	176 – 280 V
Mains frequency	0 / 50 / 60 Hz
Output current tolerance (normal operation 100 %)®	± 7.5 %
Typ. current ripple (at 230 V, 50 Hz, full load)	± 15 %
Max. repetitive output peak current	output current + 24 %
Max. non-repetitive output peak current	output current + 24 %
Power factor at full load®	0.99
Power factor at min. load®	0.97C
Turn on time (at 230 V, 50 Hz, full load)	≤ 0.1 s
Turn off time (at 230 V, 50 Hz, full load)	≤ 0.1 s
Hold on time at power failure (output)	0 s
Storage temperature ts	-40 ... +85 °C
Max. output voltage	60 V
Dimensions L x W x H	179 x 30 x 21 mm

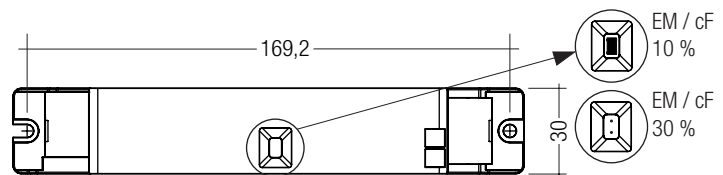
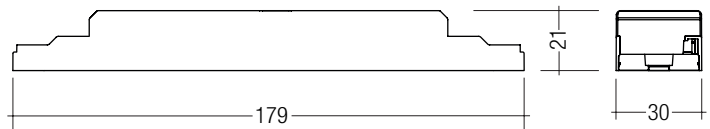

Ordering data

Type	Article number	Packaging, carton	Packaging, pallet	Weight per pc.
LCI 15W 350mA stepDIM Ip	89800277	10 pc(s).	800 pc(s).	0.064 kg
LCI 15W 500mA stepDIM Ip	89800278	10 pc(s).	800 pc(s).	0.066 kg
LCI 15W 700mA stepDIM Ip	89800279	10 pc(s).	800 pc(s).	0.065 kg



Standards, page 3

Wiring diagrams and installation examples, page 3

Specific technical data

Type	Typ. output current [Ⓢ]	Output current tolerance	Min. forward voltage	Max. forward voltage	Typ. output power	Typ. power consumption	Typ. current consumption	tc point	Ambient temperature ta
Normal operation 100 % (LCI 15W 350mA)									
LCI 15W 350mA stepDIM Ip	350 mA	± 7.5 %	21.0 V	46.0 V	16.0 W	20.0 W	89 mA	90 °C	-25 ... +50 °C
Operation cF / EM 30 % (LCI 15W 350mA)									
LCI 15W 350mA stepDIM Ip	105 mA	± 25 %	21.0 V	46.0 V	4.8 W	6.2 W	60 mA	90 °C	-25 ... +50 °C
Operation cF / EM 10 % (LCI 15W 350mA)									
LCI 15W 350mA stepDIM Ip	35 mA	± 25 %	21.0 V	46.0 V	1.6 W	2.7 W	19 mA	90 °C	-25 ... +50 °C
Normal operation 100 % (LCI 15W 500mA)									
LCI 15W 500mA stepDIM Ip	500 mA	± 7.5 %	13.5 V	33.5 V	16.5 W	20.5 W	86 mA	85 °C	-25 ... +55 °C
Operation cF / EM 30 % (LCI 15W 500mA)									
LCI 15W 500mA stepDIM Ip	150 mA	± 25 %	13.5 V	33.5 V	4.9 W	6.3 W	57 mA	85 °C	-25 ... +55 °C
Operation cF / EM 10 % (LCI 15W 500mA)									
LCI 15W 500mA stepDIM Ip	50 mA	± 25 %	13.5 V	33.5 V	1.7 W	3.0 W	20 mA	85 °C	-25 ... +55 °C
Normal operation 100 % (LCI 15W 700mA)									
LCI 15W 700mA stepDIM Ip	700 mA	± 7.5 %	10.0 V	21.5 V	15.0 W	19.0 W	84 mA	85 °C	-25 ... +55 °C
Operation cF / EM 30 % (LCI 15W 700mA)									
LCI 15W 700mA stepDIM Ip	210 mA	± 25 %	10.0 V	21.5 V	4.5 W	5.8 W	51 mA	85 °C	-25 ... +55 °C
Operation cF / EM 10 % (LCI 15W 700mA)									
LCI 15W 700mA stepDIM Ip	70 mA	± 25 %	10.0 V	21.5 V	1.5 W	3.0 W	21 mA	85 °C	-25 ... +55 °C

[Ⓢ] Test result at 230 V, 50 Hz.

[Ⓢ] Output current is mean value.

Standards

- EN 55015
- EN 61000-3-2
- EN 61000-3-3
- EN 61347-1
- EN 61347-2-13
- EN 61547
- EN 62384

Overload protection

If the output voltage range is exceeded the LED Driver reduces the LED output current. After elimination of the overload the nominal operation is restored automatically.

Short-circuit behaviour

In case of a short circuit on the secondary side (LED) the LED Driver switches into hic-cup mode. After the removal of the short-circuit fault the LED Driver will recover automatically.

No-load operation

The LED Driver works in constant current mode. In no-load operation there is the max. output voltage at the output (see page 1).

Installation instructions

Note the requirements set out in the document LED_driver_installation_advise.pdf (<http://www.tridonic.com/com/en/technical-data.asp>).

Hot plug-in or secondary switching of LEDs is not permitted and may cause a very high current to the LEDs.

Glow wire test

according to IEC 60695-2-11 with increased of 850 °C passed.

Maximum loading of automatic circuit breakers

Automatic circuit breaker type	C10				C13				C16				C20				Inrush current		
	Installation Ø	1.5 mm ²	1.5 mm ²	1.5 mm ²	2.5 mm ²	1.5 mm ²	1.5 mm ²	1.5 mm ²	2.5 mm ²	1.5 mm ²	1.5 mm ²	1.5 mm ²	2.5 mm ²	1.5 mm ²	1.5 mm ²	1.5 mm ²	2.5 mm ²	I _{max}	Time
LCI 15W 350mA step-DIM Ip	50	65	80	100	50	65	80	100	50	65	80	100	2 A	70 µs					
LCI 15W 500mA step-DIM Ip	50	65	80	100	50	65	80	100	50	65	80	100	2 A	70 µs					
LCI 15W 700mA step-DIM Ip	50	65	80	100	50	65	80	100	50	65	80	100	2 A	70 µs					

Wiring diagram with sensor

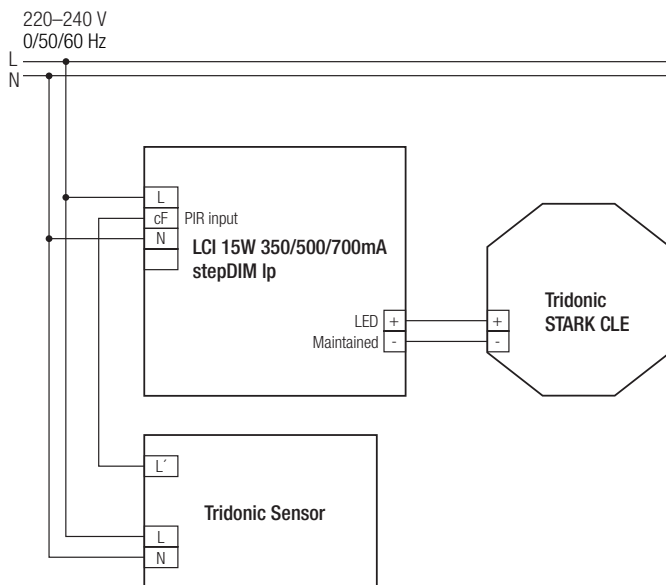

Switching behaviour:

L	cF	Jumper	Output LED
off	off	set / not set	off
off	on	set / not set	off
on	off	set	10 %
on	off	not set	30 %
on	on	set / not set	100 %

DC operation behaviour:

Emergency level at 10 %

The sensor is not active in DC operation.

Wiring diagram normal operation with EM mode

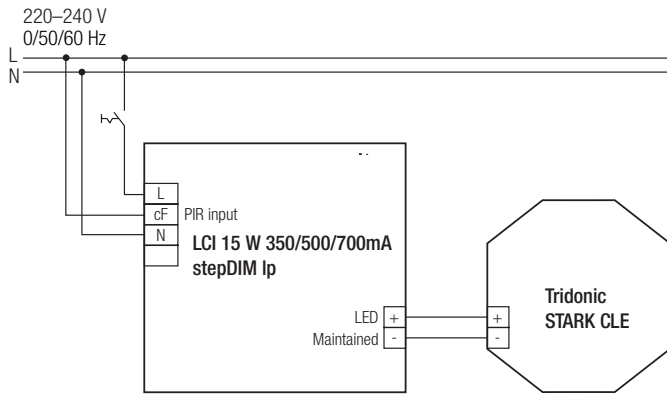

PIR input 230 V

The mains power must be removed before changing the LED load.

Secondary switching of LEDs is not allowed and may cause damage to the LEDs.

Electrical connections

Wiring

LED module/LED Driver/supply

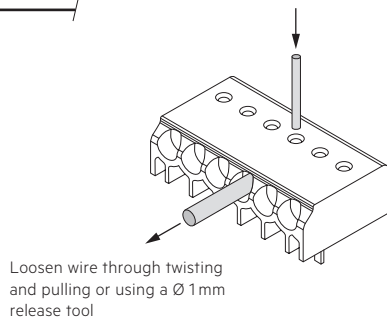
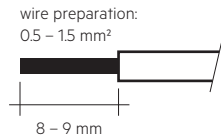

Wiring type and cross section

Solid wire with a cross section of 0.5 – 1.5 mm². Strip 8 – 9 mm of insulation from the cables to ensure perfect operation of terminals.

Mounting of device

Max. torque for fixing: 0.5Nm/M4

DC operation behaviour:

The emergency level (10 % or 100 %) depends on the polarity of the DC voltage.

L	+	-	+	-
N	-	+	-	+
CF	+	-	-	+
Emergency level	100 %	10 / 30 %*	10 / 30 %*	100 %

* depending on the jumper setting (set: 10 %, not set: 30 %)

Wiring guidelines

- All connections must be kept as short as possible to ensure good EMI behaviour.
- Mains leads should be kept apart from LED Driver and other leads (ideally 5 – 10 cm distance)
- Max. length of output wires is 30 cm.
- Incorrect wiring can damage LED modules.
- The wiring must be protected against short circuits to earth (sharp edged metal parts, metal cable clips, louver, etc.).

Isolation and electric strength testing of luminaires

Electronic devices can be damaged by high voltage. This has to be considered during the routine testing of the luminaires in production.

According to IEC 60598-1 Annex Q (informative only!) or ENEC 303-Annex A, each luminaire should be submitted to an isolation test with 500 V_{DC} for 1 second. This test voltage should be connected between the interconnected phase and neutral terminals and the earth terminal.

The isolation resistance must be at least 2 MΩ.

As an alternative, IEC 60598-1 Annex Q describes a test of the electrical strength with 1500 V_{AC} (or 1.414 x 1500 V_{DC}). To avoid damage to the electronic devices this test must not be conducted.

Additional information

Additional technical information at www.tridonic.com → Technical Data

Guarantee conditions at www.tridonic.com → Services

Life-time declarations are informative and represent no warranty claim. No warranty if device was opened.