



Engine DLE AC G3 one4all PRE

Engine DLE

Product description

- Module with integrated electronics
- For downlights
- Light engine operating with 220 – 240 V AC
- Dimming range 1 – 100 %
- one4all (DALI, DSI, switchDIM, corridorFUNCTION)
- Overtemperature protection
- Luminous flux range from 2,000 / 3,000 lm
- High system efficacy up to 111 lm/W at $t_p = 65\text{ }^\circ\text{C}$
- Nominal life-time up to 50,000 h (L70/F10)
- Small colour tolerance MacAdam 3
- Fixing holes for M4 screws
- Dimmable
- Cooling required
- 5-year guarantee



Standards, page 4

Colour temperatures and tolerances, page 9



Engine DLE AC G3 one4all PRE

Engine DLE

Technical data

Rated supply voltage	220 – 240 V
Input voltage range	198 – 264 V
Mains current (at 230 V, 50 Hz, full load) 2,000 lm [®]	78 mA
Mains current (at 230 V, 50 Hz, full load) 3,000 lm [®]	126 mA
Leakage current (PE)	< 0.28 mA
Mains frequency	50 / 60 Hz
Overvoltage protection	275 V continuous
Typ. λ (at 230 V, 50 Hz, full load)	0.95
THD	< 17 %
Flicker	< 10 %
Typ. power input on stand-by	< 0.5 W
Time to light (at 230 V, 50 Hz, full load)	< 0.65 s
Turn off time (at 230 V, 50 Hz, full load)	< 1 s
Beam characteristic	80°
Ambient temperature ta	-25 ... +45 °C
Typ. tp temperature ^①	65 °C
Max. tc point temperature ^①	80 °C
Dimming range	1 – 100 %
Mains surge capability (between L – N)	1 kV
Mains surge capability (between L/N – PE)	2 kV
ESD classification	severity level 4
Risk group (EN 62471:2008)	RG 1
Classification acc. to IEC 62031	Built-in
Type of protection	IP20

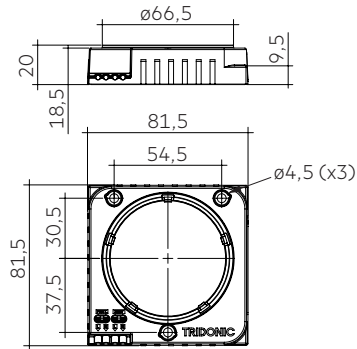

Ordering data

Type	Article number	Colour temperature	Casing	Packaging [®]	Weight per pc.
DLE AC G3 60MM 2000LM 830 o4a PRE	89602990	3,000 K	yes	10 pc(s).	0.06 kg
DLE AC G3 60MM 2000LM 840 o4a PRE	89602991	4,000 K	yes	10 pc(s).	0.06 kg
DLE AC G3 60MM 3000LM 830 o4a PRE	89602992	3,000 K	yes	10 pc(s).	0.06 kg
DLE AC G3 60MM 3000LM 840 o4a PRE	89602993	4,000 K	yes	10 pc(s).	0.06 kg

Specific technical data

Type	Photometric code	Luminous flux at tp = 25 °C ^②	Luminous flux at tp = 65 °C ^②	Input power [®]	Luminous efficacy system at tp = 65 °C	Colour rendering index CRI	Energy classification
DLE AC G3 60mm 2000lm o4a PRE							
DLE AC G3 60MM 2000LM 830 o4a PRE	830/359	2,100 lm	2,000 lm	18 W	111 lm/W	80	A+
DLE AC G3 60MM 2000LM 840 o4a PRE	840/359	2,100 lm	2,000 lm	18 W	111 lm/W	80	A+
DLE AC G3 60mm 3000lm o4a PRE							
DLE AC G3 60MM 3000LM 830 o4a PRE	830/359	3,100 lm	3,000 lm	29 W	103 lm/W	80	A+
DLE AC G3 60MM 3000LM 840 o4a PRE	840/359	3,100 lm	3,000 lm	29 W	103 lm/W	80	A+

^① If the max. temperature limits are exceeded, the life of the system will be greatly reduced or the system may be damaged.
The temperature of the LED module at the tp-point is to be measured in the thermally stable state with a temperature sensor or temperature-sensitive sticker as per EN 60598-1. For the precise position of the tp point see the drawing on page 4.

^② Tolerance range for optical data: ±10 %.

[®] All values at tp = 65 °C.

[®] Orders only in full carton quantities.

Measured at 230 V / 50 Hz.

Product description

- The adapter plate does not replace a heat sink

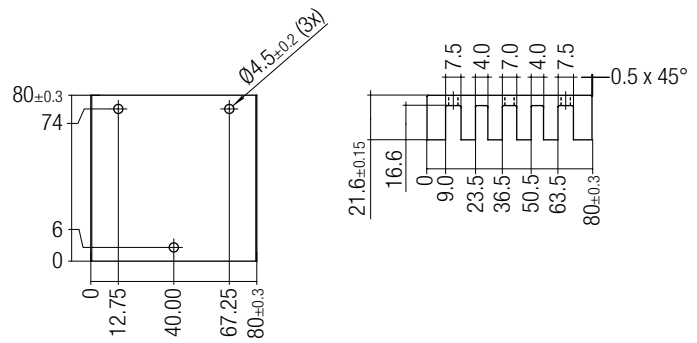
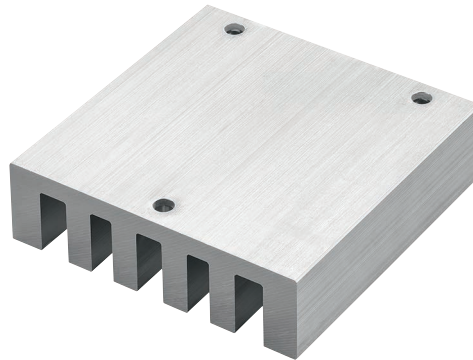

Ordering data

Type	Article number	Packaging	Weight per pc.
DLE GEN2 Adapter	28000420	1 pc(s).	0.250 kg

1. Standards

EN 55015
EN 61000-3-2
EN 61000-3-3
EN 61547
EN 62031
EN 62386-101
EN 62386-102
EN 62386-207
EN 62471
EN 62778

Lamp failure detection not possible, because of integrated light source.

1.1 Glow wire test

according to EN 60695-2-11 with increased temperature of 650 °C passed.

1.2 Photometric code

Key for photometric code, e. g. 830 / 469

1 st digit	2 nd + 3 rd digit	4 th digit	5 th digit	6 th digit
Code CRI	Colour temperature in Kelvin x 100	MacAdam initial	MacAdam after 25% of the life-time (max.6000h)	Luminous flux after 25% of the life-time (max.6000h)
7 70 – 79				Code Luminous flux
8 80 – 89				7 ≥ 70 %
9 ≥90				8 ≥ 80 %
				9 ≥ 90 %

1.3 Isolation and electric strength testing of luminaires

Electronic devices can be damaged by high voltage. This has to be considered during the routine testing of the luminaires in production.

According to IEC 60598-1 Annex Q (informative only!) or ENEC 303-Annex A, each luminaire should be submitted to an isolation test with 500 V_{DC} for 1 second. This test voltage should be connected between the inter-connected phase and neutral terminals and the earth terminal. The isolation resistance must be at least 2 MΩ.

As an alternative, IEC 60598-1 Annex Q describes a test of the electrical strength with 1500 V_{AC} (or 1.414 x 1500 V_{DC}). To avoid damage to the electronic devices this test must not be conducted.

2. Thermal details

2.1 tp point, ambient temperature and life-time

The temperature at tp reference point is crucial for the light output and life-time of a LED module.

The operating temperature of a LED module is crucial for the light output, the product life-time but also for the product safety.

The thermal limits can be checked at the tp/tc point and at tr.

On page 6 the lumen maintenance is shown in relation to the temperature at tp, tp, rated shows the temperature at which the rated values are reached.

tc shows the thermal limit for safety reason and must never be exceeded under normal conditions.

For DLE AC G3 o4a PRE a tp temperature of 65 °C has to be complied in order to achieve an optimum between heat sink requirements, light output and life-time.

Compliance with the maximum permissible reference temperature at the tp point must be checked under operating conditions in a thermally stable state. The maximum value must be determined under worst-case conditions for the relevant application.

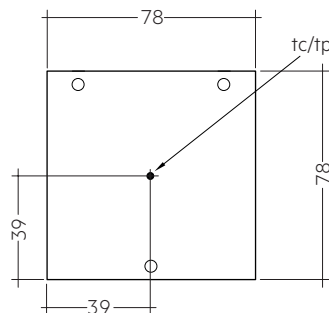

DLE AC G3 o4a PRE

2.2 Storage and humidity

storage temperature	-30 ... +80 °C
---------------------	----------------

Operation only in non condensing environment.

Humidity during processing of the module should be between 30 to 70 %.

2.3 Thermal design and heat sink

The rated life of LED products depends to a large extent on the temperature. If the permissible temperature limits are exceeded, the life of the DLE AC G3 o4a PRE will be greatly reduced or the DLE AC G3 o4a PRE may be destroyed.

Therefore the DLE AC G3 o4a PRE needs to be mounted onto a heat sink heat sink which does not exceed the value for R_{th,max}.

Tridonic's excellent thermal design for the DLE AC G3 o4a PRE products provides the lowest thermal resistance and therefore allowing new compact designs without sacrificing quality, safety and life-time.

2.4 Heat sink values

DLE AC G3 2000LM o4a PRE

ta	tp	R _{th, hs-a}
25 °C	65 °C	2.83 K/W
35 °C	65 °C	2.12 K/W
45 °C	65 °C	1.41 K/W
55 °C	65 °C	0.70 K/W
60 °C	65 °C	0.35 K/W

DLE AC G3 3000LM o4a PRE

ta	tp	R _{th, hs-a}
25 °C	65 °C	1.81 K/W
35 °C	65 °C	1.36 K/W
45 °C	65 °C	0.90 K/W
55 °C	65 °C	0.45 K/W
60 °C	65 °C	0.22 K/W

Notes

The actual cooling can differ because of the material, the structural shape, outside influences and the installation situation. A thermal connection between DLE AC G3 o4a PRE and heat sink with heat-conducting paste or heat conducting adhesive film is absolutely necessary.

Additionally the DLE AC G3 o4a PRE has to be fixed on the heat sink with M4 screws to optimise the thermal connection.

Use of thermal interface material with thermal conductivity of $\lambda > 1 \text{ W/mK}$ and layer thickness of interface material with max. 50 µm or a similar interface material where the quotient of layer thickness and thermal conductivity $b < 50 \text{ µmmK/W}$.

3. Installation / wiring

3.1 Electrical supply/choice of LED Driver

DLE AC G3 o4a PRE from Tridonic are protected against mains transients up to 1kV.

The DLE AC G3 o4a PRE has to be operated with 220 – 240 V AC, 50 / 60 Hz.

3.2 Wiring

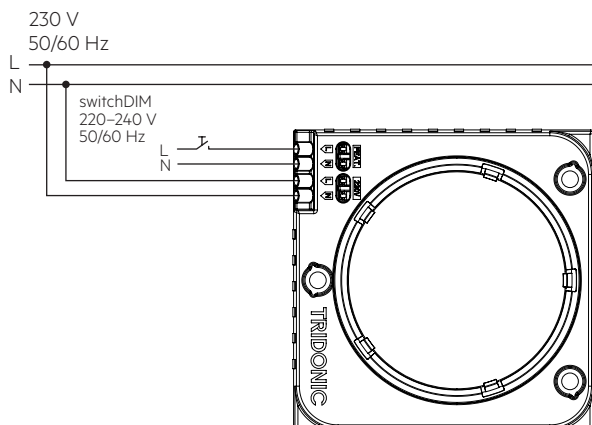
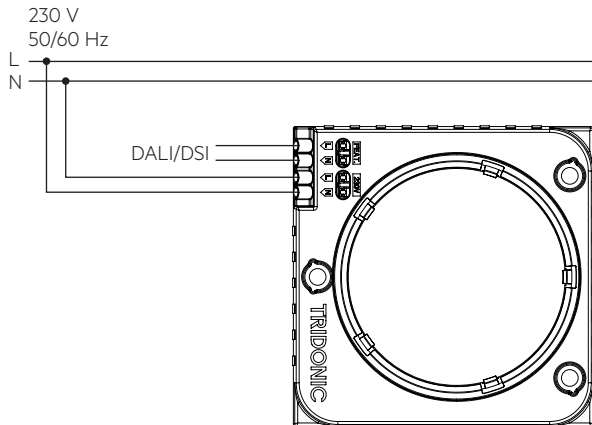

3.3 Release of the wiring

Press down the “push button” and remove the cable from front.

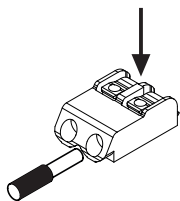

3.4 Wiring type and cross section

The wiring can be solid or stranded wires with a cross section of 0.25 to 0.75 mm². For the push-wire connection you have to strip the insulation (7–9 mm). Loosen wire through twisting and pulling.

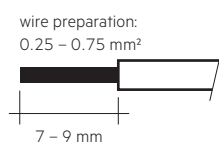

3.5 Mounting instruction



In case DLE AC G3 o4a PRE modules are mounted into a protection class I luminaire, heat sink and lamp housing must be earthed.

In case DLE AC G3 o4a PRE modules are mounted into a protection class II luminaire, the LED module and all conductive parts in electric connection (like heat sink, etc.) must be untouchable.



DLE AC G3 o4a PRE from Tridonic which have to be installed on a heat sink have to be connected with heat-conducting paste or heat conducting adhesive film and fixed with M4 screws.

The fixing/cooling surface must be cleaned before installing the LED to remove all dirt, dust and grease.

None of the components of the DLE AC G3 o4a PRE (substrate, LED, electronic components etc.) may be exposed to tensile or compressive stresses.



Max. torque for fixing with M4 screws: 1.2 Nm.
Don't use countersunk screw.

The modules are mounted with 3 screws per module.
In order not to damage the modules only rounded head screws should be used.



Chemical substance may harm the LED module. Chemical reactions could lead to colour shift, reduced luminous flux or a total failure of the module caused by corrosion of electrical connections.

Materials which are used in LED applications (e.g. sealings, adhesives) must not produce dissolver gas. They must not be condensation curing based, acetate curing based or contain sulfur, chlorine or phthalate.

Avoid corrosive atmosphere during usage and storage.

3.6 EOS/ESD safety guidelines



The device / module contains components that are sensitive to electrostatic discharge and may only be installed in the factory and on site if appropriate EOS/ESD protection measures have been taken. No special measures need be taken for devices/modules with enclosed casings (contact with the pc board not possible), just normal installation practice. Please note the requirements set out in the document EOS / ESD guidelines (Guideline_EOS_ESD.pdf) at: <http://www.tridonic.com/esd-protection>

4. Interfaces / communication

4.1 Control input (DA/N, DA/L)

Digital DALI signal or switchDIM can be wired on the same terminals (DA/N and DA/L).

The control input is non-polar for digital control signals (DALI, DSI). The control signal is not SELV. Control cable has to be installed in accordance to the requirements of low voltage installations.

Different functions depending on each module.

4.2 switchDIM

Integrated switchDIM function allows a direct connection of a pushbutton for dimming and switching.

Brief push (< 0.6 s) switches LED Driver ON and OFF. The dimm level is saved at power-down and restored at power-up.

When the pushbutton is held, LED modules are dimmed. After repush the LED modules are dimmed in the opposite direction.

In installations with LED Drivers with different dimming levels or opposite dimming directions (e.g. after a system extension), all LED Drivers can be synchronized to 50 % dimming level by a 10 s push.

Use of pushbutton with indicator lamp is not permitted.

4.3 corridorFUNCTION

The corridorFUNCTION can be programmed in two different ways.

To program the corridorFUNCTION by means of software a DALI-USB interface is needed in combination with a DALI PS. The software can be the masterCONFIGURATOR.

To activate the corridorFUNCTION without using software a voltage of 230 V has to be applied for five minutes at the switchDIM connection.

The unit will then switch automatically to the corridorFUNCTION.

Note:

If the corridorFUNCTION is wrongly activated in a switchDIM system (for example a switch is used instead of pushbutton), there is the option of installing a pushbutton and deactivating the corridorFUNCTION mode by five short pushes of the button within three seconds.

switchDIM and corridorFUNCTION are very simple tools for controlling gears with conventional pushbuttons or motion sensors.

To ensure correct operation a sinusoidal mains voltage with a frequency of 50 Hz or 60 Hz is required at the control input.

Special attention must be paid to achieving clear zero crossings. Serious mains faults may impair the operation of switchDIM and corridorFUNCTION.

5. Life-time

5.1 Life-time, lumen maintenance and failure rate

The light output of an LED module decreases over the life-time, this is characterized with the L value.

L70 means that the LED module will give 70 % of its initial luminous flux.

This value is always related to the number of operation hours and therefore defines the life-time of an LED module.

As the L value is a statistical value and the lumen maintenance may vary over the delivered LED modules.

The B value defines the amount of modules which are below the specific L value, e.g. L70B10 means 10 % of the LED modules are below 70 % of the initial luminous flux, respectively 90 % will be above 70 % of the initial value.

In addition the percentage of failed modules (fatal failure) is characterized by the C value.

The F value is the combination of the B and C value. That means for F degradation and complete failures are considered, e.g. L70F10 means 10 % of the LED modules may fail or be below 70 % of the initial luminous flux.

5.2 Lumen maintenance

Life-time declarations are informative and represent no warranty claim.

tp temperature	L70 / F10	L70 / F50	L80 / F10	L80 / F50	L90 / F10	L90 / F50
60 °C	>50,000 h	>50,000 h	33,000 h	49,000 h	17,000 h	24,000 h
70 °C	>50,000 h	>50,000 h	33,000 h	48,000 h	17,000 h	24,000 h
80 °C	>50,000 h	>50,000 h	33,000 h	40,000 h	17,000 h	20,000 h

6. Electrical values

6.1 Maximum loading of automatic circuit breakers

Automatic circuit breaker type	C10	C13	C16	C20	B10	B13	B16	B20	Inrush current
Installation Ø	1.5 mm ²	1.5 mm ²	1.5 mm ²	2.5 mm ²	1.5 mm ²	1.5 mm ²	1.5 mm ²	2.5 mm ²	I _{max} time
DLE AC G3 2000Im o4a PRE	90	125	155	200	56	75	95	120	15 A 100 µs
DLE AC G3 3000Im o4a PRE	75	100	120	150	56	75	95	120	15 A 100 µs



No considerable inrush current, therefore the amount of devices per circuit breaker is restricted by max. input current.

6.2 Harmonic distortion in the mains supply (at 230 V / 50 Hz and full load) in %

	THD	3.	5.	7.	9.
DLE AC G3 2000Im o4a PRE	<15	<12	<4	<1	<4
DLE AC G3 3000Im o4a PRE	<15	<12	<4	<1	<4

6.3 Typ. light output vs. tc temperature

DLE AC G3 o4a PRE 2,000 lm

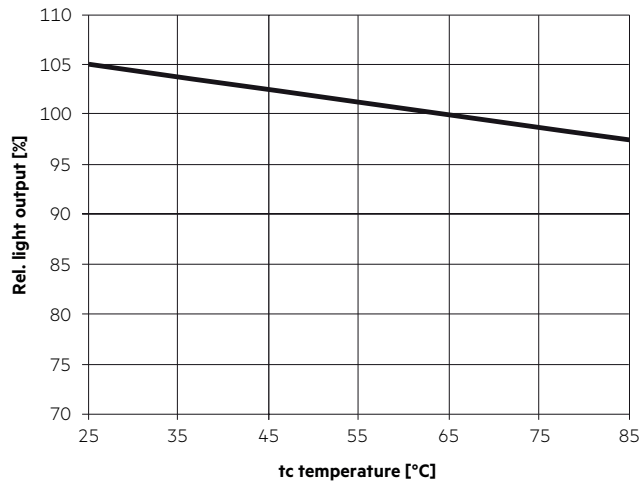

DLE AC G3 o4a PRE 3,000 lm

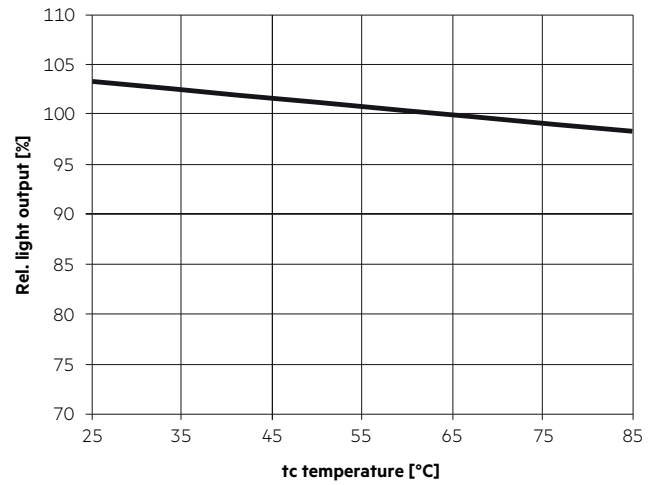

6.4 Typ. efficiency vs. tc temperature

DLE AC G3 o4a PRE 2,000 lm

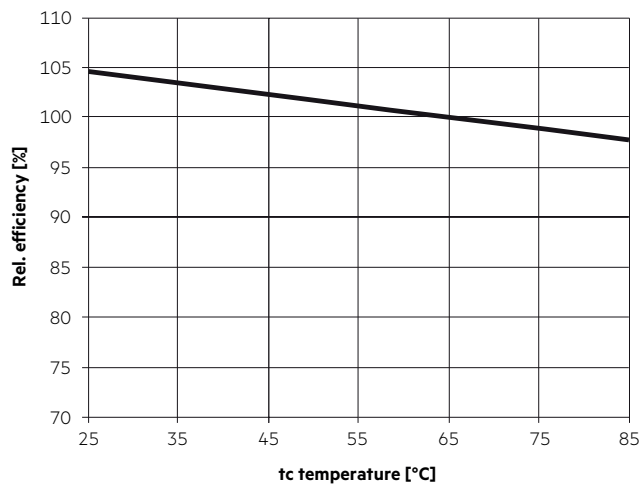

DLE AC G3 o4a PRE 3,000 lm

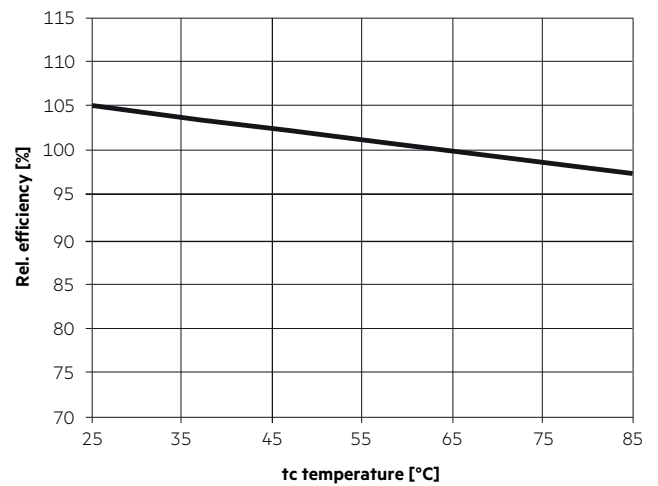

6.5 Typ. light output vs. operating voltage

DLE AC G3 o4a PRE 2,000 lm

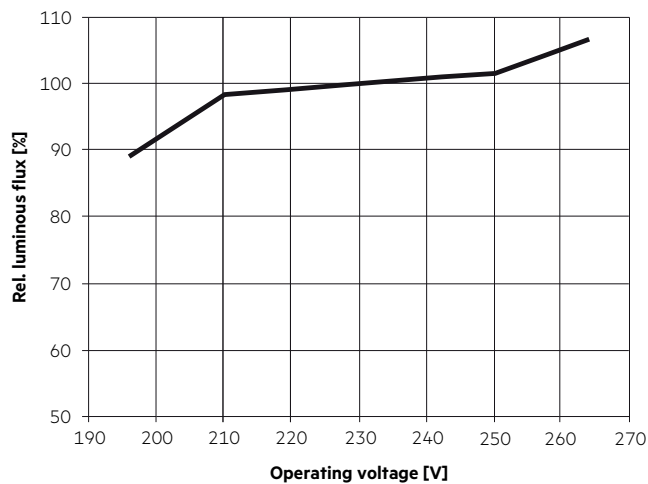

DLE AC G3 o4a PRE 3,000 lm

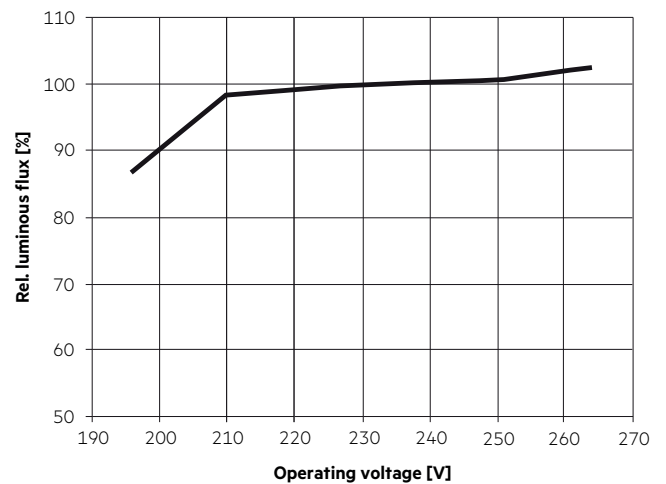

6.6 Typ. efficiency vs. operating voltage

DLE AC G3 o4a PRE 2,000 lm

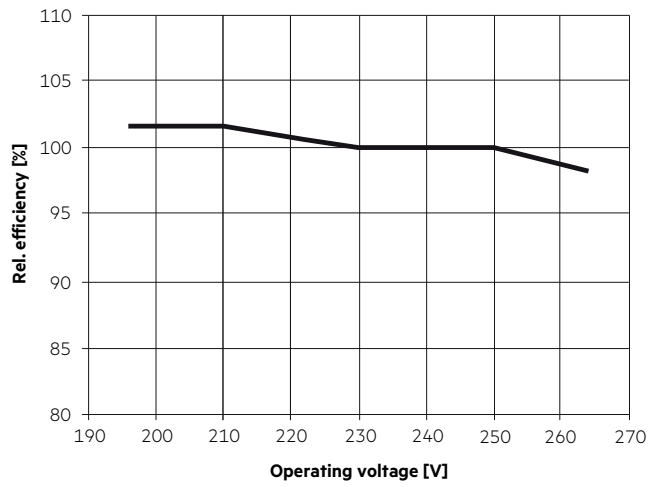

DLE AC G3 o4a PRE 3,000 lm

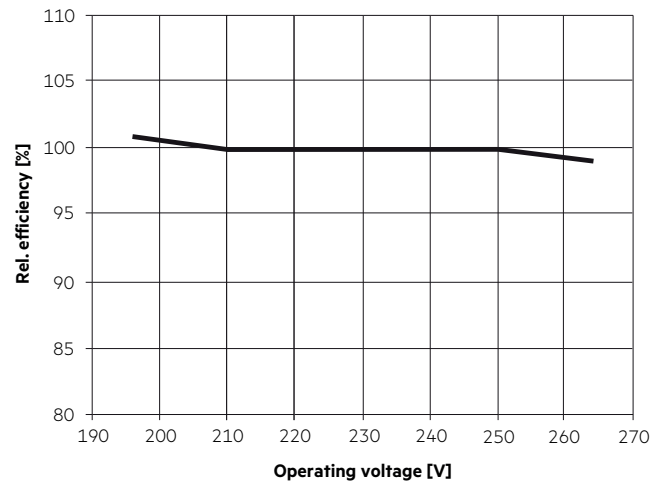

6.7 Power consumption vs. operating voltage

DLE AC G3 o4a PRE 2,000 lm

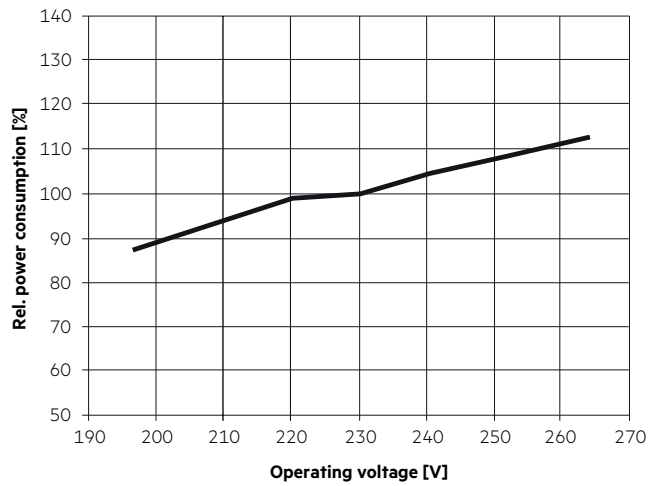

DLE AC G3 o4a PRE 3,000 lm

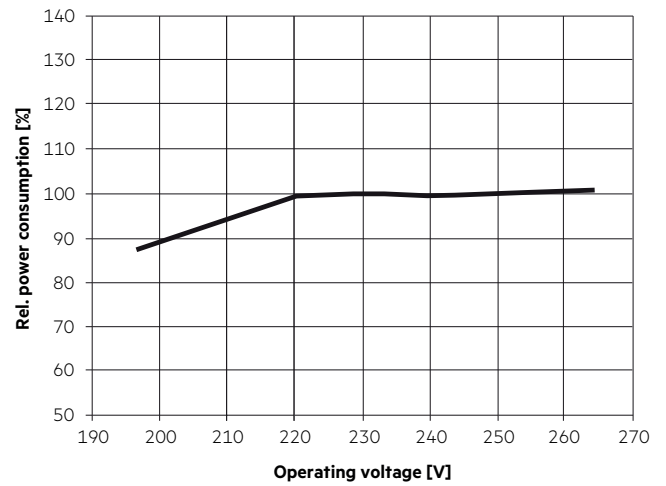

7. Photometric characteristics

7.1 Coordinates and tolerances according to CIE 1931

The specified colour coordinates are measured integral after a settling time of 100 ms. The current impuls depends on the module type. The ambient temperature of the measurement is $t_a = 25^\circ\text{C}$. The measurement tolerance of the colour coordinates are ± 0.01 .

3,000 K

	x0	y0
Centre	0.4388	0.4080

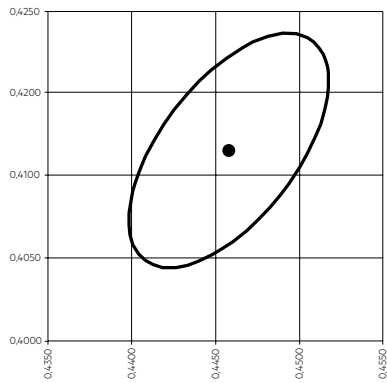

MacAdam ellipse: 3SDCM

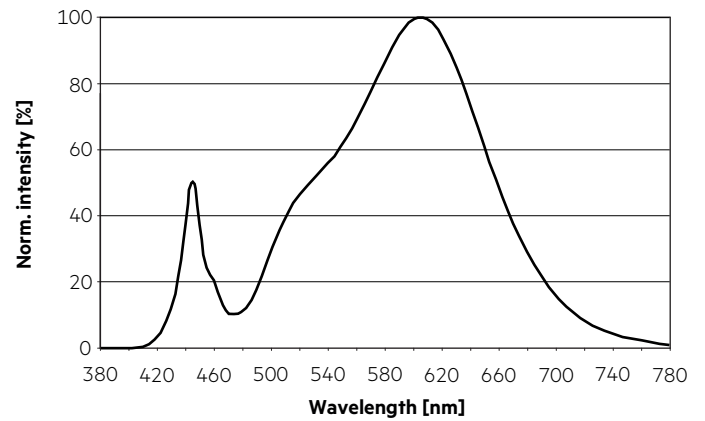

4,000 K

	x0	y0
Centre	0.3878	0.3897

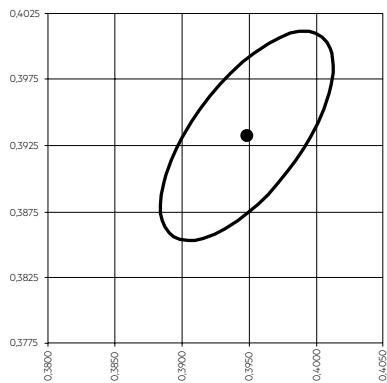

MacAdam ellipse: 3SDCM

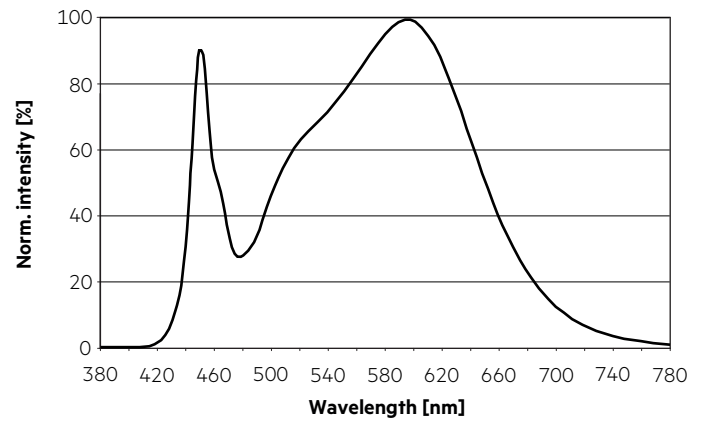

7.2 Light distribution

