

CLE premium system data sheet

CLE premium

Product description

- Ideal for round shaped ceiling and pendant luminaires
- Circular Tunable White system with adjustable colour temperature from 3,000 to 6,000 K at constant luminous flux
- Precalibrated set to ensure premium light quality and colour consistency, consisting of LED Driver and 4 or 8 LED modules^①
- Outstanding system colour tolerance MacAdam 3 over the full operating area
- Dimming range 10 – 100 % without change of colour temperature
- High system efficiency up to 166 lm/W at tp = 45 °C
- Low-profile LED Driver with digital interface (DALI Device Type 8, DSI, switchDIM, colourTEMPERATURE)
- Self cooling (no additional heat sink required)
- Long life-time of 50,000 h and 5-year system guarantee



Technical data CLE premium, page 2

Product description CLE premium, page 5

Technical data LCAI TW Ip, page 4

Product description LCAI TW Ip, page 12

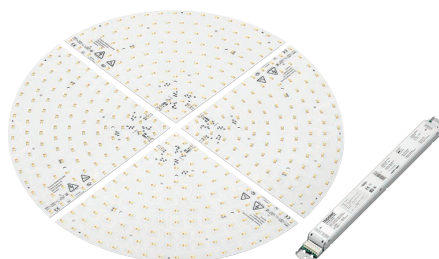

TW CLE G1 261mm 4x1150lm 830-860 PRE KIT



TW CLE G1 401mm 4x2450lm 830-860 PRE KIT

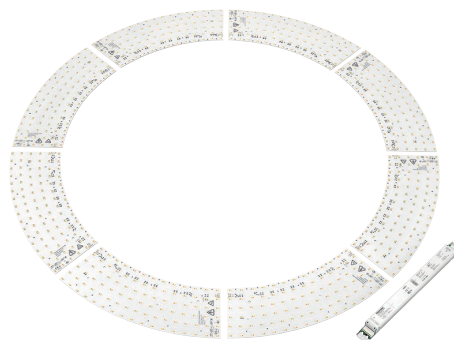

TW CLE G1 541mm 8x900lm 830-860 PRE KIT

Ordering data

Type	Article number	System components
TW CLE G1 261mm 4x1150lm 830-860 PRE KIT	89602612	1 LED Driver + 4 LED modules at 1,150 lm
TW CLE G1 401mm 4x2450lm 830-860 PRE KIT	89602613	1 LED Driver + 4 LED modules at 2,450 lm
TW CLE G1 541mm 8x900lm 830-860 PRE KIT	89602614	1 LED Driver + 8 LED modules at 900 lm

Specific technical data

Type	Photometric code	Typ. forward current ^②	Typ. luminous flux at tp = 25 °C ^②	Typ. luminous flux at tp = 45 °C ^②	Typ. power consumption at tp = 45 °C ^③	Efficacy of the system at tp = 25 °C	Efficacy of the system at tp = 45 °C	Colour rendering index CRI ^④	Energy classification
TW CLE G1 261mm 4x1150lm 830-860 PRE	830/349 – 860/349	125 mA	4,770 lm	4,650 lm	28.4 W	161 lm/W	160 lm/W	> 80	A++
TW CLE G1 401mm 4x2450lm 830-860 PRE	830/349 – 860/349	250 mA	9,860 lm	9,610 lm	58.0 W	163 lm/W	162 lm/W	> 80	A++
TW CLE G1 541mm 8x900lm 830-860 PRE	830/349 – 860/349	250 mA	7,600 lm	7,410 lm	43.5 W	167 lm/W	166 lm/W	> 80	A++

^① Mixing of components from different sets is not allowed due to the pre-calibration of the system.

^② Tolerance range for optical data over the CCT range: ±5 %.

^③ Tolerance range for electrical data: ±5 %.

^④ Colour temperature and CRI according to CIE 1931.



Module CLE premium

CLE premium

Product description

- Tunable White LED module with adjustable colour temperature
- High colour rendering index CRI > 80
- Small colour tolerance MacAdam 3
- Narrow luminous flux tolerances
- Excellent thermal management
- Ideal for panel lights
- Long life-time: 50,000 hours
- 5-year guarantee

Technical data

Beam characteristic	120°
Ambient temperature range	-25 ... 55 °C
tp rated	45 °C
tc	95 °C
Irated for TW CLE G1 261mm	125 mA
Irated for TW CLE G1 401mm	250 mA
Irated for TW CLE G1 541mm	250 mA
I _{max} for TW CLE G1 261mm	900 mA
I _{max} for TW CLE G1 401mm	1,650 mA
I _{max} for TW CLE G1 541mm	1,950 mA
Max. DC forward current for TW CLE G1 261mm	990 mA
Max. DC forward current for TW CLE G1 401mm	1,815 mA
Max. DC forward current for TW CLE G1 541mm	2,145 mA
Max. permissible LF current ripple for TW CLE G1 261mm	1,080 mA
Max. permissible LF current ripple for TW CLE G1 401mm	1,980 mA
Max. permissible LF current ripple for TW CLE G1 541mm	2,340 mA
Max. permissible peak current for TW CLE G1 261mm	1,440 mA / max. 10 ms
Max. permissible peak current for TW CLE G1 401mm	2,640 mA / max. 10 ms
Max. permissible peak current for TW CLE G1 541mm	3,120 mA / max. 10 ms
Max. working voltage for insulation ²⁾	400 V
Insulation test voltage	1.8 kV
CTI of the printed circuit board	≥ 600
ESD classification	severity level 4
Risk group (EN 62471:2008)	1
Type of protection	IPO0



Standards, page 4

Colour temperatures and tolerances, page 7

Product description, page 4

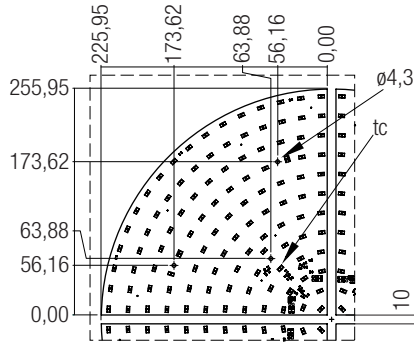

TW CLE G1 261mm 4x1150lm 830-860 PRE KIT

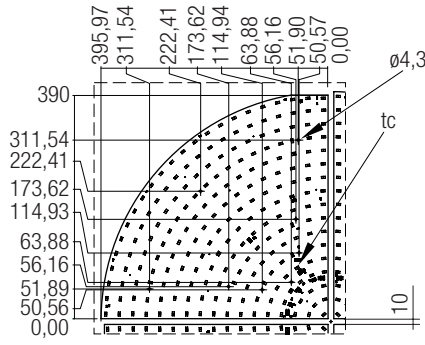
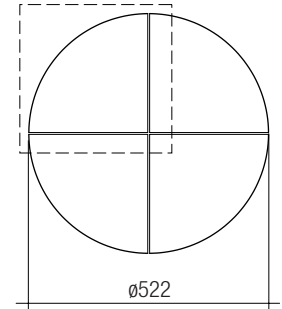

TW CLE G1 401mm 4x2450lm 830-860 PRE KIT

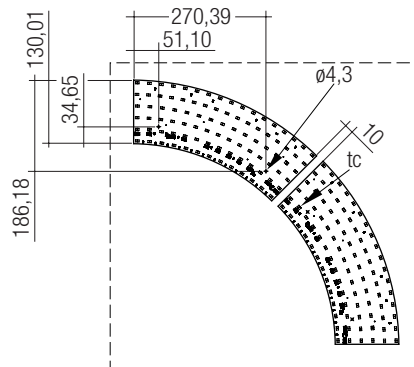
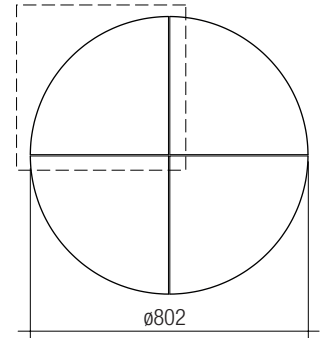

TW CLE G1 541mm 8x900lm 830-860 PRE KIT

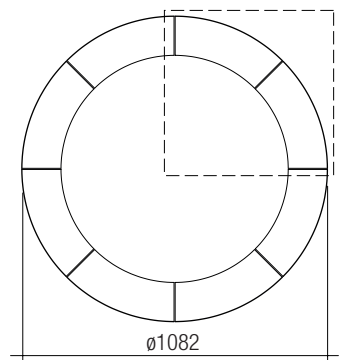

Specific technical data

Type	Channel	Photometric code	Typ. luminous flux at tp = 25 °C ^①	Typ. luminous flux at tp = 45 °C ^①	Typ. forward current ^②	Min. forward voltage at tp = 45 °C ^②	Max. forward voltage at tp = 25 °C ^②	Typ. power consumption at tp = 45 °C ^②	Efficacy of the module at tp = 25 °C	Efficacy of the module at tp = 45 °C	Colour rendering index CRI ^③
CLE G1 261mm 1150lm PRE	WW	827/xxx	1,120 lm	1,090 lm	125 mA	44.9 V	50.7 V	5.9 W	186 lm/W	182 lm/W	80
	CW	865/xxx	1,190 lm	1,160 lm	125 mA	44.9 V	50.7 V	5.9 W	198 lm/W	196 lm/W	80
CLE G1 401mm 2450lm PRE	WW	827/xxx	2,350 lm	2,290 lm	250 mA	47.6 V	53.7 V	12.5 W	185 lm/W	183 lm/W	80
	CW	865/xxx	2,520 lm	2,460 lm	250 mA	47.6 V	53.7 V	12.5 W	198 lm/W	187 lm/W	80
CLE G1 541mm 900lm PRE	WW	827/xxx	870 lm	850 lm	250 mA	17.5 V	19.8 V	4.6 W	185 lm/W	182 lm/W	80
	CW	865/xxx	930 lm	900 lm	250 mA	17.5 V	19.8 V	4.6 W	198 lm/W	196 lm/W	80

^① Tolerance range for optical data over the CCT range: ±5 %.

^② Tolerance range for electrical data: ±5 %.

^③ CRI according to CIE 1931.

IP20       

Driver LCAI TW Ip

Product description

- LED Driver for CLE premium modules
- Output power: 38 W or 75 W
- Power input on standby < 0.3 W

Properties

- Low-profile LED Driver with digital interface (DALI Device Type 8, DSI, switchDIM, colourTEMPERATURE)
- switchDIM and colourTEMPERATURE with memory function^{①②}
- Powerless switching via digital interface (no need for switching via mains)
- Intelligent Temperature Guard (protection against thermal damage)
- Short-circuit shutdown feature with one restart (after 0.5 s)
- Overload protection with one restart (after 0.5 s)

Technical data

Rated supply voltage	220 – 240 V
Input voltage range, AC	198 – 264 V
Input voltage range, DC	176 – 280 V
Rated current (at 230 V 50 Hz) for 38 W	0.18 A
Rated current (at 230 V 50 Hz) for 75 W	0.35 A
Mains frequency	0 / 50 / 60 Hz
Efficiency for 38 W	90 %
Efficiency for 75 W	93 %
λ (at 230 V 50 Hz, full load)	0.96
Control input ^{①②}	DSI, DALI, switchDIM, colourTEMPERATURE
Stand-by power	< 0.3 W
Max. output voltage (no-load voltage)	270 V
Dimming range	10 – 100 %
PWM frequency	200 – 500 Hz
Set up time (at 230 V 50 Hz)	< 0.5 s
Switchover time AC/DC and DC/AC	< 1 s
Leakage current (PE)	150 μ A
t_a operating (at life-time 50,000 h) for 38 W	-25 ... +60 °C
t_a operating (at life-time 50,000 h) for 75 W	-25 ... +55 °C
Max. casing temperature t_c (at life-time 50,000 h) for 38 W	70 °C
Max. casing temperature t_c (at life-time 50,000 h) for 75 W	75 °C

^① In DC operation the last set colour is used.

^② No colourTEMPERATURE mode at DC operation.

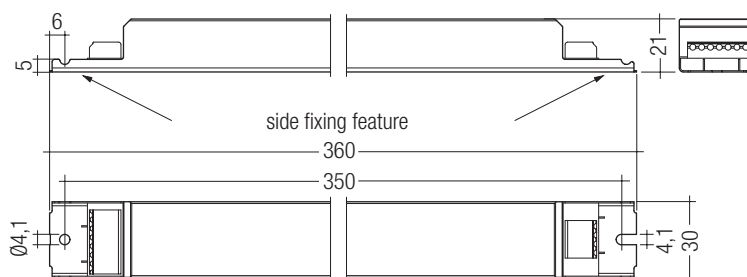

Product description, page 8

Module CLE premium

Product description

Standards

IEC 62031
IEC 62471
IEC 61547

Photometric code

Key for photometric code, e. g. 830 / 349

1 st digit		2 nd + 3 rd digit	4 th digit	5 th digit	6 th digit	
Code	CRI	Colour temperature in Kelvin x 100	MacAdam initial	MacAdam after 25% of the life-time (max.6000h)	Luminous flux after 25% of the life-time (max.6000h)	
					Code	Luminous flux
7	70 – 79				7	≥ 70 %
8	80 – 89				8	≥ 80 %
9	≥90			9	≥ 90 %	

Thermal design and heat sink

The rated life of LED products depends to a large extent on the temperature. If the permissible temperature limits are exceeded, the life of the CLE will be strongly reduced or even destroyed.

tc point, ambient temperature and life-time

The temperature at tp reference point is crucial for the light output and life-time of a LED product.

For CLE a tp temperature of 45 °C has to be complied in order to achieve an optimum between heat sink requirements, light output and life-time.

Compliance with the maximum permissible reference temperature at the tc point must be checked under operating conditions in a thermally stable state. The maximum value must be determined under worst-case conditions for the relevant application.

The tc and tp temperature of LED modules from Tridonic are measured at the same reference point.

There are two reference points on the module t1, t2 (one for each channel). There are additional reference points on the big modules t3 to tx. In thermal critical luminaires they should be used.

Mounting instruction



None of the components of the CLE (substrate, LED, electronic components etc.) may be exposed to tensile or compressive stresses.

Max. torque for fixing: 0.5 Nm.

The LED modules are mounted with 4 screws per module. In order not to damage the modules only rounded head screws and an additional plastic flat washer should be used.



Chemical substance may harm the LED module. Chemical reactions could lead to colour shift, reduced luminous flux or a total failure of the module caused by corrosion of electrical connections.

Materials which are used in LED applications (e.g. sealings, adhesives) must not produce dissolver gas. They must not be condensation curing based, acetate curing based or contain sulfur, chlorine or phthalate. Avoid corrosive atmosphere during usage and storage.



EOS/ESD safety guidelines

The device / module contains components that are sensitive to electrostatic discharge and may only be installed in the factory and on site if appropriate EOS/ESD protection measures have been taken. No special measures need be taken for devices/modules with enclosed casings (contact with the pc board not possible), just normal installation practice. Please note the requirements set out in the document EOS / ESD guidelines (Guideline_EOS_ESD.pdf) at: <http://www.tridonic.com/esd-protection>

Selection of the LED Driver

CLE premium can only be operated with the LED Driver LCAI TW Ip.



Only components out of a single set shall be connected. Mixing the sets will invalidate the system calibration and will decrease the system performance considerably.

The PWM signal induces magnetic forces on the wiring that may cause vibrations, depending on the luminaire wiring and setup.

Possible solutions:

- Reduce the length of the negative terminal wires
- The wiring of the individual channels has to be separated
- Use of twisted pairs is not recommended
- Use of thicker wires

Due to the converter topology, the LED packages of the modules are glowing if the system is turned off by DALI (DALI=0).

Storage and humidity

Storage temperature	-30... +80 °C
---------------------	---------------

Operation only in non condensing environment.

Humidity during processing of the module should be between 30 to 70 %.

Life-time, lumen maintenance and failure rate

The light output of an LED module decreases over the life-time, this is characterized with the L value. L70 means that the LED module will have 70 % of its initial luminous flux after the stated operating time. This value is always related to the number of operation hours and therefore defines the life-time of an LED module.

As the L value is a statistical value the lumen maintenance may vary over the delivered LED modules. The B value defines the amount of modules which are below the specific L value, e.g. L70B10 means 10 % of the LED modules are below 70 % of the initial luminous flux, respectively 90 % will be above 70 % of the initial value. In addition the percentage of failed modules (fatal failure) is characterized by the C value.

The F value is the combination of the B and C value. That means for F degradation and complete failures are considered, e.g. L70F10 means 10 % of the LED modules may fail or be below 70 % of the initial luminous flux.

Lumen maintenance for CLE

tp temperature	L90 / F10	L90 / F50	L80 / F10	L80 / F50	L70 / F10	L70 / F50
45 °C	50,000 h	50,000 h	50,000 h	50,000 h	50,000 h	50,000 h
50 °C	50,000 h	50,000 h	50,000 h	50,000 h	50,000 h	50,000 h
55 °C	50,000 h	50,000 h	50,000 h	50,000 h	50,000 h	50,000 h
60 °C	42,600 h	50,000 h	50,000 h	50,000 h	50,000 h	50,000 h
65 °C	31,500 h	50,000 h	50,000 h	50,000 h	50,000 h	50,000 h

Wiring diagram for switchDIM and colourTEMPERATURE for CLE premium (with 4 or 8 modules)

TW CLE G1 261mm 4x1150lm

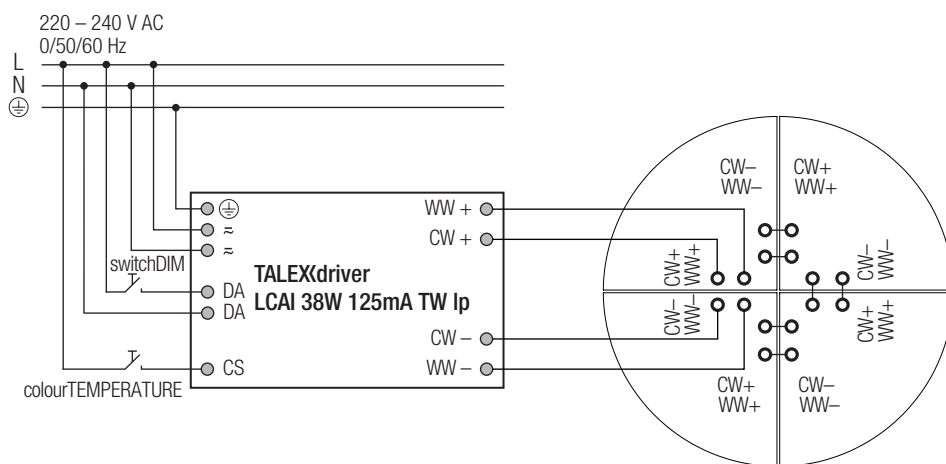

TW CLE G1 401mm 4x2450lm

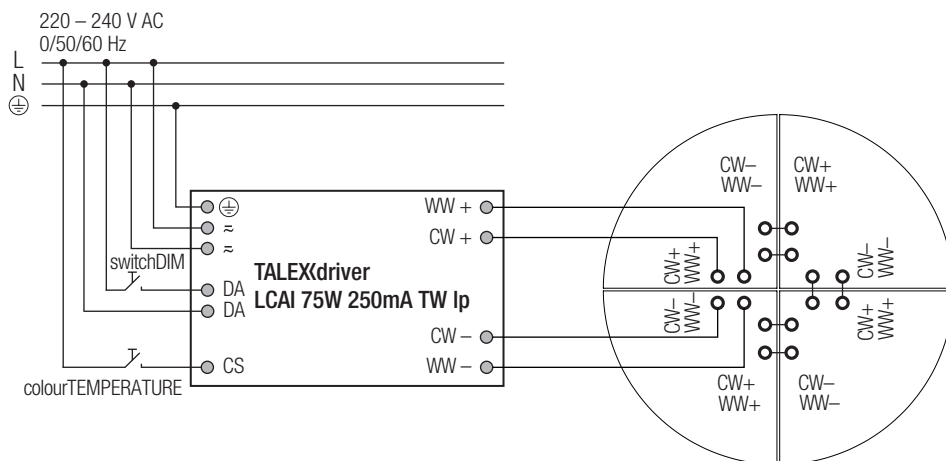

TW CLE G1 541mm 8x900lm

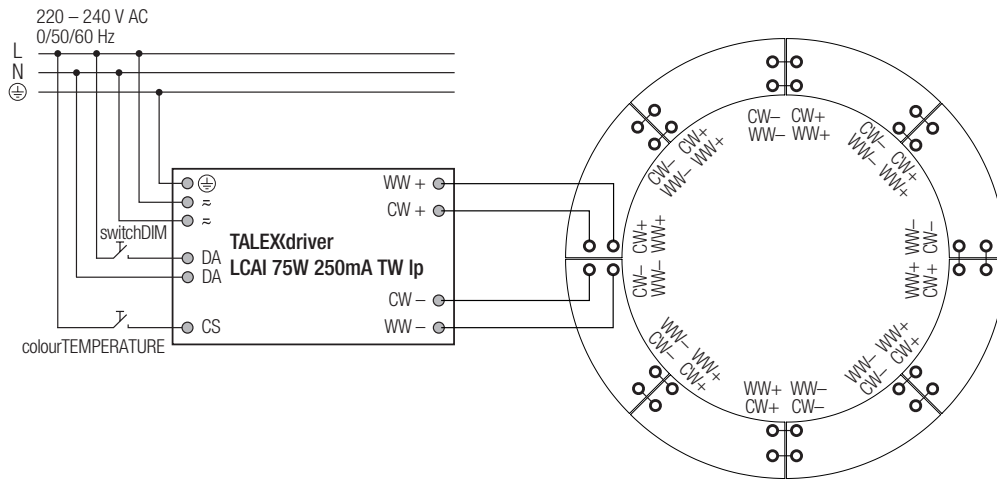

Wiring diagram for DALI for CLE premium (with 4 or 8 modules)

TW CLE G1 261mm 4x1150lm

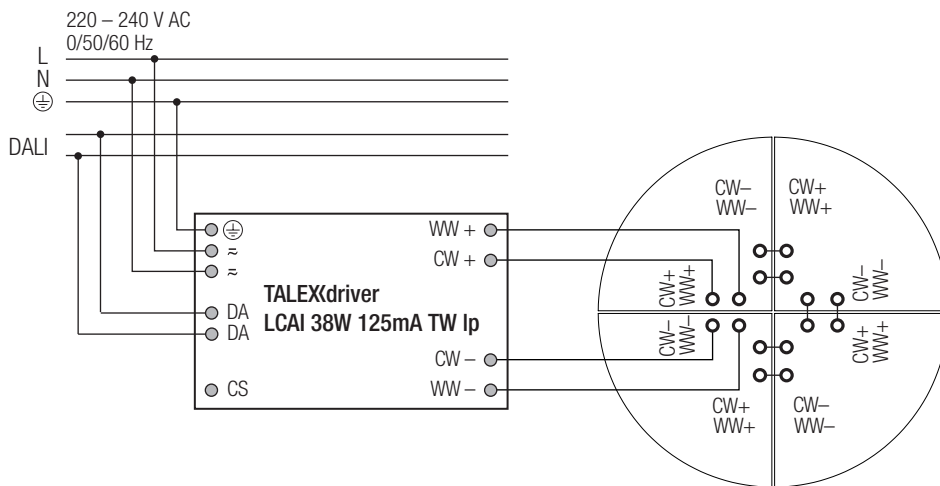

TW CLE G1 401mm 4x2450lm

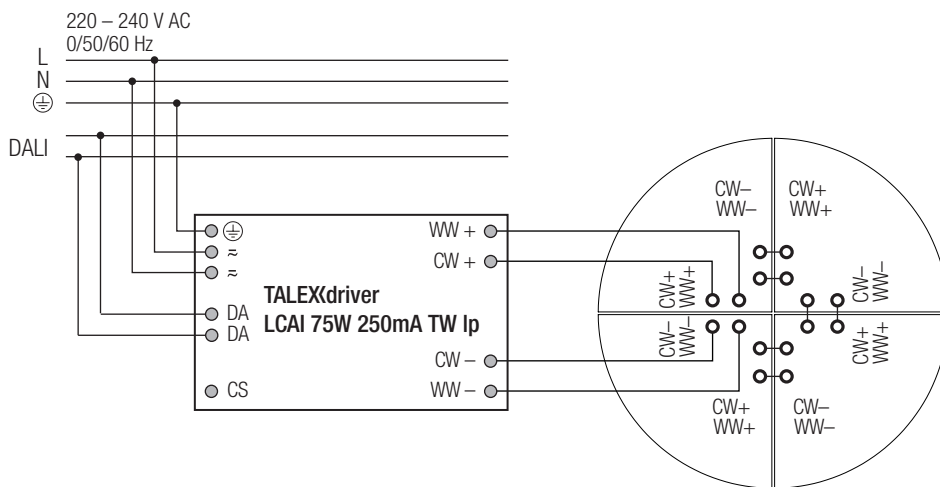

TW CLE G1 541mm 8x900lm

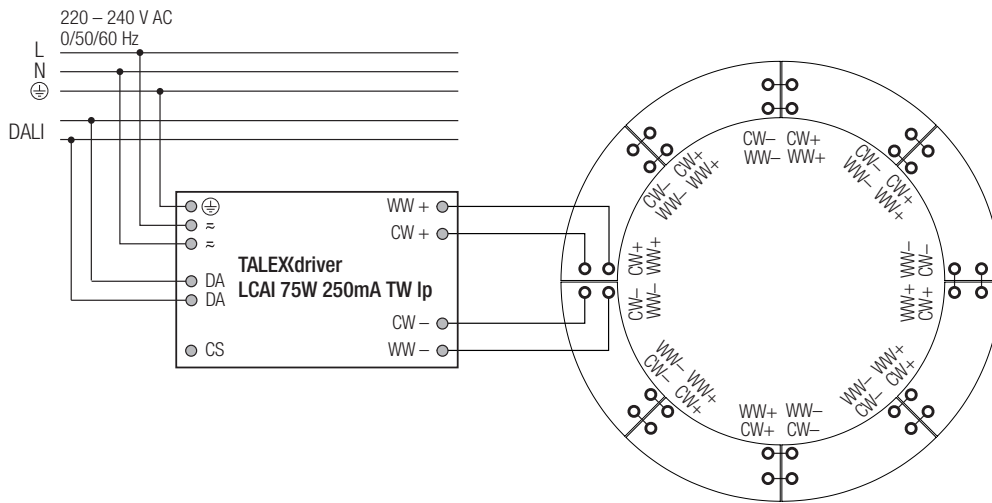

Wiring type and cross section of the LED module

The wiring can be solid cable with a cross section of 0.14 to 0.5 mm².
For the push-wire connection you have to strip the insulation (4–5.5 mm).

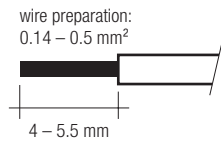

Loosen wire through twisting and pulling.

Declaration of electrical parameters

Irated ... Nominal operating current the module is designed for.

I_{max} ... Max. permissible continuous operating current.

Max. DC forward current ... Max. permissible continuous operating current incl. The tolerances of the LED driver. LED module may be destroyed if this value is exceeded.

Max. permissible LF current ripple ... Max. output current of the LED driver incl. Tolerances and LF current ripple must not exceed this value.

Max. permissible peak current ... The max. output peak current of the LED driver must not exceed this value.

Relative light flux vs. operating temperature

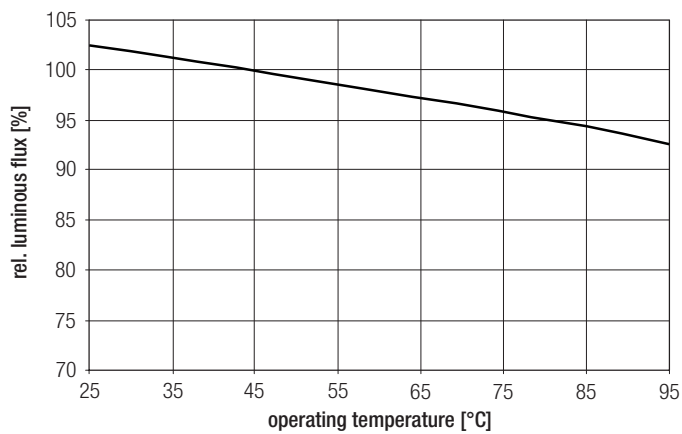

Typ. forward voltage vs. forward current

TW CLE G1 261mm 4x1150lm

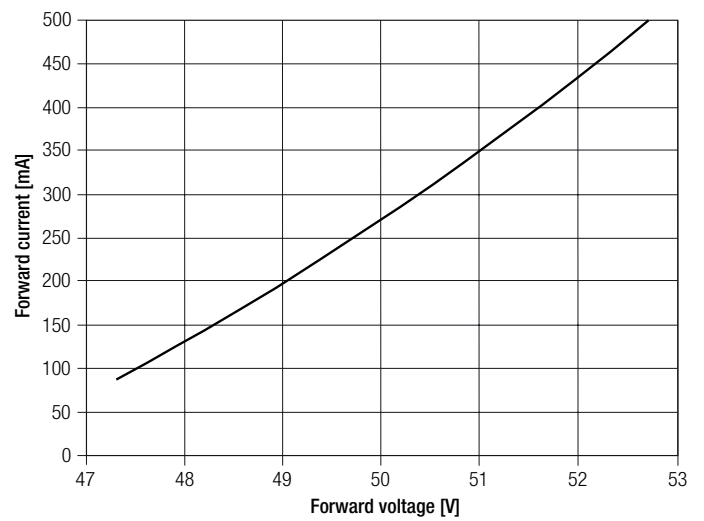

Relative luminous flux vs. operating current

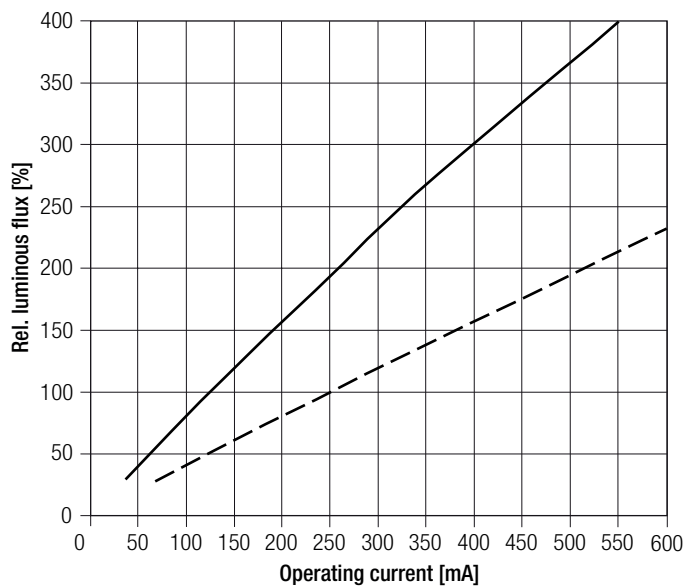

TW CLE G1 401mm 4x2450lm

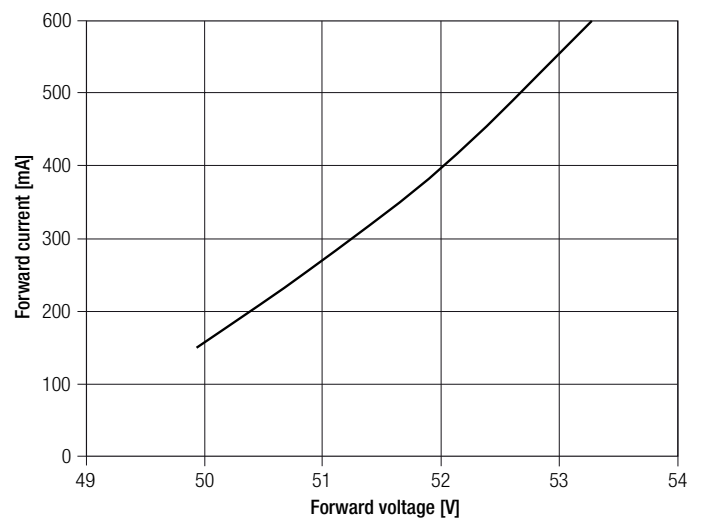

— TW CLE G1 261mm 4x1150lm
 - - - TW CLE G1 401mm 4x2450lm / TW CLE G1 541mm 8x900lm

The diagrams are based on statistic values.

TW CLE G1 541mm 8x900lm

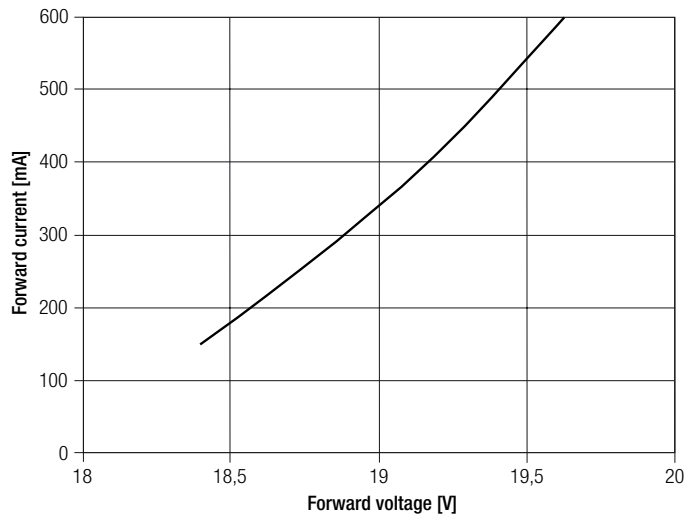

The diagrams are based on statistic values.

Optical characteristics CLE

The optical design of the CLE product line ensures optimum homogeneity for the light distribution.

Light distribution

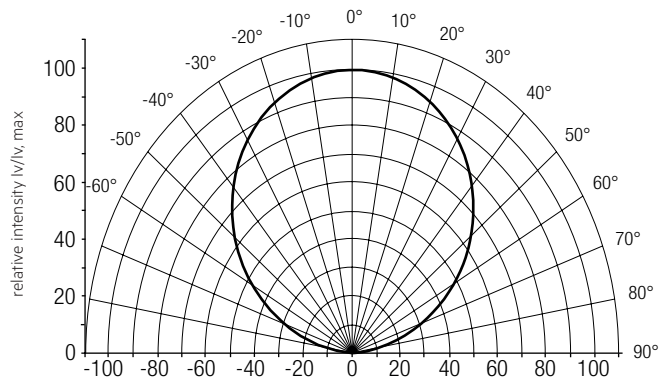

The colour temperature is measured integral over the complete module.
To ensure an ideal mixture of colours and a homogeneous light distribution a suitable optic (e. g. PMMA diffuser) and a sufficient spacing between module and optic (typ. 6 cm) should be used.

For further information see Design-in Guide, 3D data and photometric data on www.tridonic.com or on request.

Coordinates and tolerances according to CIE 1931

The specified colour coordinates are central measured by a current impulse with typical values of module and a duration of 100 ms.
The ambient temperature of the measurement is $t_a = 25^\circ\text{C}$.
The measurement tolerance of the colour coordinates are ± 0.01 .

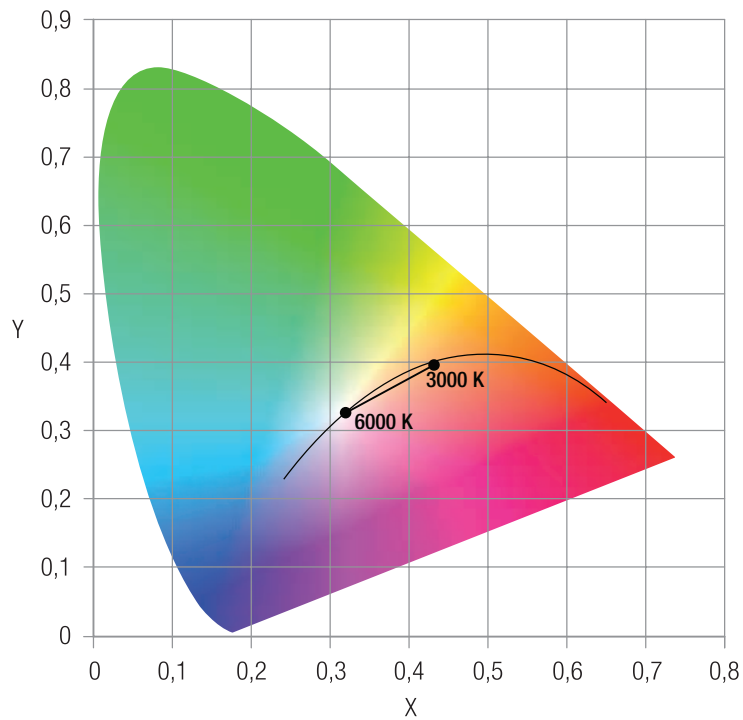

3,000 K

	x0	y0
Centre	0.4325	0.3955

6,000 K

	x0	y0
Centre	0.3220	0.3330

MacAdam ellipse: 3SDCM

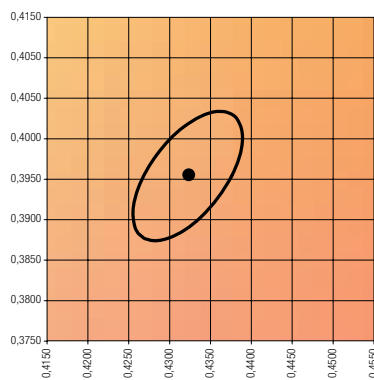

MacAdam ellipse: 3SDCM

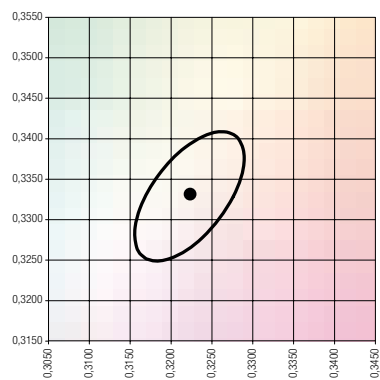

Colour spectrum at different colour temperatures

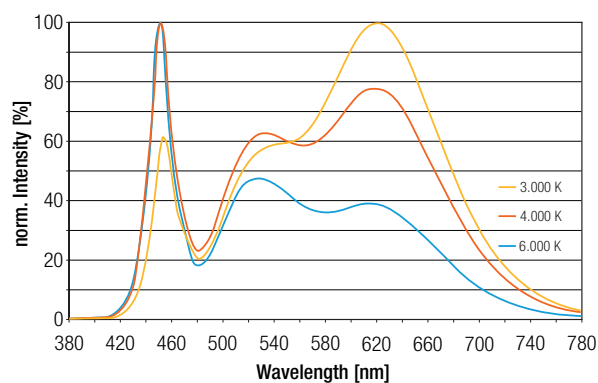

Driver LCAI TW Ip
Product description

Standards

- EN 61347-1
- EN 61347-2-13
- EN 62384
- EN 61000-3-2
- EN 61547
- EN 55015
- EN 62493
- EN 62386-101
- EN 62386-102
- EN 62386-209 (DALI DEVICE Type 8)

Control input (DA/D1, DA/D2)

Digital DALI/DSI signal or switchDIM can be wired on the same terminals (DA/D1 and DA/D2).

Digital signal DALI/DSI

The control input is non-polar and protected against accidental connection with a mains voltage up to 264 V. The control signal is not SELV. Control cable has to be installed in accordance to the requirements of low voltage installations.
Different functions depending on each module.

Colour types

Supported colour types according to DALI Device Type 8:

- colour temperature (colourTEMPERATURE)

Thermal protection of the unit

The unit also has an ITG (Intelligent Temperature Guard). This protects the LED Driver LCAI TW Ip from thermal overload by reducing the output power or switching off in case of operation above the thermal limits of the luminaire or ballast. Depending on the luminaire design, the ITG operates at about 12 °C (±5 °C) above tc temperature.

Control via switchDIM and colourTEMPERATURE

A conventional double pushbutton can be used to control the system via switchDIM and colourTEMPERATURE. One of the pushbuttons is used to set the colour temperature, the other to set the dimming level.



Pushbuttons with glow lamps affect the switchDIM and colourTEMPERATURE and should therefore not be used for this purpose.

For control via a double pushbutton different settings can be made:

- Setting the colour temperature via colourTEMPERATURE mode with 7 predefined values between 3,000 and 6,000 K.
- Stepless setting of the dimming level between 10 and 100 %.
- These values can be changed via masterCONFIGURATOR.

colourTEMPERATURE mode

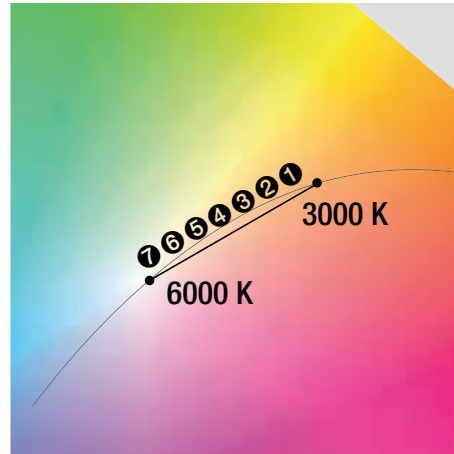

Location of the predefined colour temperatures

1	3.000 K
2	3.500 K
3	4.000 K
4	4.500 K
5	5.000 K
6	5.500 K
7	6.000 K

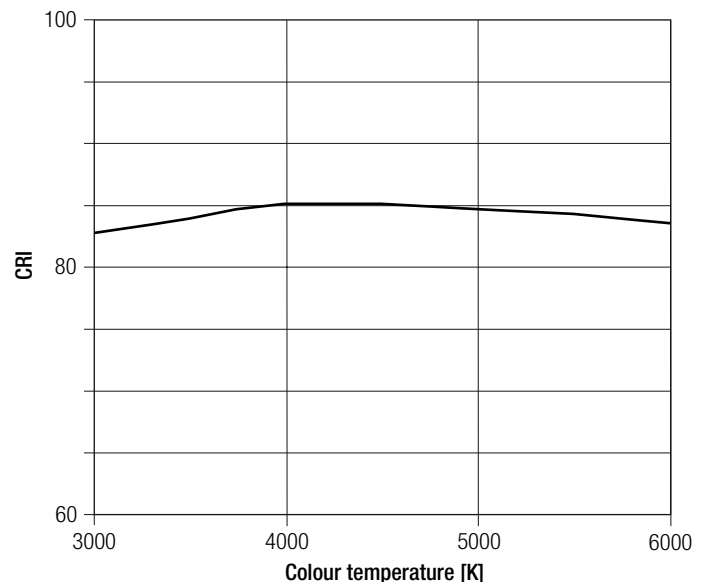

Setting the colour temperature

The procedure for setting the colour temperature mode (colourTEMPERATURE):

- Press the pushbutton briefly (approx. 1 s) to advance the colour temperature by one step



When reaching the maximum value the LED module will flash shortly. Another press on the pushbutton will switch the colour temperature immediately to the minimum value.

- Alternatively the colour temperature can be changed via DALI device type 8 control system.

For further information please refer to the brochure entitled "Technical Design-In-Guide CLE premium".

Dimming

Dimming range 10 % to 100 %

Digital control with:

- DSI signal: 8 bit Manchester Code
Speed 10 % to 100 % in 1.4 s
- DALI signal: 16 bit Manchester Code
Speed 10 % to 100 % in 0.1 s
Programmable parameter:
Minimum dimming level
Maximum dimming level
Default minimum = 10 %
Programmable range 10 % ≤ MIN ≤ 100 %
Default maximum = 100 %
Programmable range 100 % ≥ MAX ≥ 10 %

Dimming curve is adapted to the eye sensitiveness.

Dimming characteristics

Digital dimming value

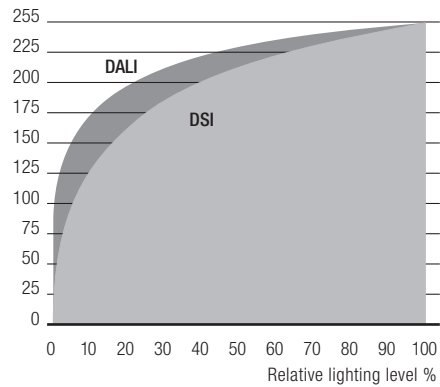

Dimming characteristics as seen by the human eye

Label



The LLE PRE TW KIT components form a matched and calibrated unit. Therefore it is not allowed to separate and operate the components in different combinations! There is a label on the LED Driver LCAI TW Ip with the corresponding module information.

Code: 89601938
Type: STARK-LLE-3x24-280-700-830-860-PRE-KIT
Sys. Batch: 1234567 / Module Batch: 1234567
Only use with matching LED modules!
Module Nr.: 99.9 / 99.9 / 99.9 / 99.9 / 99.9
Date: XX.XX.XXXX

PRI CS DALI DSI	TRIDONIC LCAI 75W 250mA TW Ip Art. No. 86459554 200mA-300mA Constant Current LED Control Gear Digital Dimmable	 	 emergency supply voltage Nominal: 220V Range: 176V ... 280V emergency information and wiring see datasheet *CS = colour switch L000 0000 0000000	wire preparation: 0,5 - 1,5 D 0 - 8mm www.tridonic.com suitable for emergency installations acc. to EN 50172	220-240V 0/50/60Hz 230V 0,35A -0.98 ta: -25°C ... +60°C tc: +70°C Pout max: 75W Uout max: 270V LED voltage: 125V, 250V	+WW -WW +CW -CW SEC

Maximum loading of automatic circuit breakers

Automatic circuit breaker type	C10	C13	C16	C20	B10	B13	B16	B20	Inrush current	
Installation Ø	1.5 mm ²	1.5 mm ²	1.5 mm ²	2.5 mm ²	1.5 mm ²	1.5 mm ²	1.5 mm ²	2.5 mm ²	I_{max}	time
LCAI 38 W 125 mA TW Ip	22	30	40	58	11	15	20	29	23 A	290 µs
LCAI 75 W 250 mA TW Ip	14	20	28	38	7	10	14	19	26 A	350 µs

Harmonic distortion in the mains supply (at 230 V / 50 Hz and full load) in %

Type	THD	3	5	7	9	11
LCAI 38 W 125 mA TW Ip	< 12	9	5	4	1	2
LCAI 75 W 250 mA TW Ip	< 9	6	5	4	3	2

Wiring type and cross section of the LED Driver

Solid wire with a cross section of 0.5 – 1.5 mm². Strip 8 – 9 mm of insulation from the cables to ensure perfect operation of terminals.

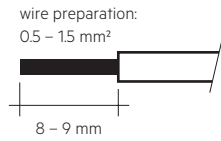

Wiring instructions

The secondary leads should be separated from the mains connections and wiring for good EMC performance.

The maximum lead length on secondary side is 1.5 m. For a good EMC performance keep the LED wiring as short as possible.

Furthermore, the wiring of the individual channels has to be separated and the use of twisted pairs is not recommended.

Release of the wiring

Loosen wire through twisting and pulling or using a Ø 1 mm release tool.

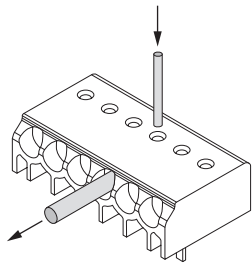

Side fixing feature

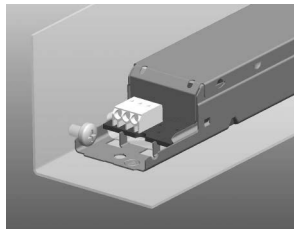

Screw M4, screw head diameter 8–10 mm

Additional information

Additional technical information at www.tridonic.com → Technical Data

Guarantee conditions at www.tridonic.com → Services

Life-time declarations are informative and represent no warranty claim.