



Driver LCA 120 W 300–1050 mA 1–10 V C ADV OTD

ADVANCED Outdoor series

Product description

- Dimmable built-in LED Driver
- Constant current LED Driver
- Output current 300 – 1,050 mA
- Max. output power 120 W
- Nominal life-time up to 100,000 h
- Dimmable via 1 ... 10 V
- Output dimmed analogue (current amplitude)
- Dimming range from 10 to 100 %
- For luminaires of protection class I and protection class II
- Temperature protection as per EN 61347-2-13 C5e
- Potted version
- 5-year guarantee



Properties

- Type of protection IP20

Functions

- Adjustable output current (I-select resistor)
- Overload protection
- Short-circuit protection
- No-load protection
- Burst protection voltage up to 6 kV
- Surge protection voltage up to 6 kV (L to N)
- Surge protection voltage up to 6 kV (L/N to earth)



Standards, page 4

Wiring diagrams and installation examples, page 5

IP20                                             

Product description

- Ready-for-use resistor to set output current value
- Compatible with LED Driver featuring I-select 2 interface; not compatible with I-select (generation 1)
- Resistor is base isolated
- Resistor power 0.25 W
- Current tolerance $\pm 2\%$ to nominal current value
- Compatible with LED Driver series PRE and EXC

Example of calculation

- $R [k\Omega] = 5 V / I_{out} [mA] \times 1000$
- Resistor value tolerance $\leq 1\%$; resistor power $\geq 0.1 W$; base isolation necessary
- When using a resistor value beyond the specified range, the output current will automatically be set to the minimum value (resistor value too big), respectively to the maximum value (resistor value too small)

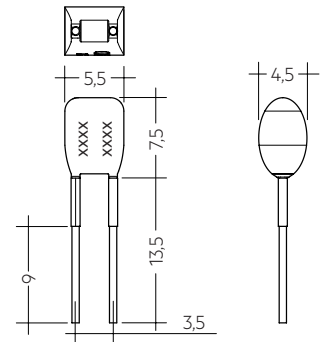
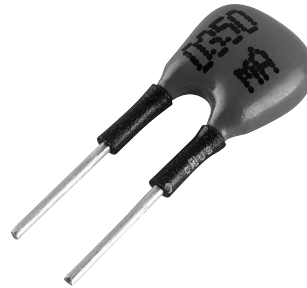

Ordering data

Type	Article number	Colour	Marking	Current	Packaging bag	Weight per pc.
I-SELECT 2 PLUG 300MA BL	28001108	Blue	0300 mA	300 mA	10 pc(s).	0.001 kg
I-SELECT 2 PLUG 500MA BL	28001114	Blue	0500 mA	500 mA	10 pc(s).	0.001 kg
I-SELECT 2 PLUG 700MA BL	28001118	Blue	0700 mA	700 mA	10 pc(s).	0.001 kg
I-SELECT 2 PLUG 900MA BL	28001122	Blue	0900 mA	900 mA	10 pc(s).	0.001 kg
I-SELECT 2 PLUG 1050MA BL	28001125	Blue	1050 mA	1,050 mA	10 pc(s).	0.001 kg
I-SELECT 2 PLUG Deactivation	28001462	Blue	-	-	10 pc(s).	0.001 kg

Standards

EN 55015 EN 61547
EN 61000-3-2 EN 62384
EN 61000-3-3
EN 61347-1
EN 61347-2-13

Overload protection

If the output voltage range is exceeded, the LED Driver reduces the LED output current. After elimination of the overload, the nominal operation is restored automatically.

Overtemperature protection

The LED Driver is protected against temporary thermal overheating. If the temperature limit is exceeded, the output current is reduced to protect the device. It restarts automatically.

Short-circuit behaviour

In case of a short circuit the LED Driver will continue providing the output current. There will be no damage to the LED Driver.

No-load operation

The LED Driver detects the open load condition and shuts the output down. There will be periodically restart attempts whereby the specified max. DC output voltage will not be exceeded.

External temperature protection (ETM)

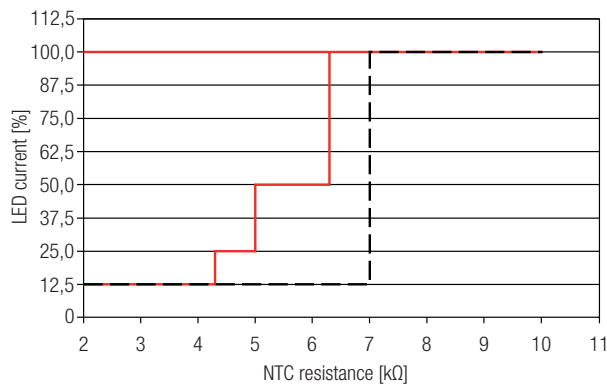

NTC resistance	Reaction
< 6.3 kΩ	System is reducing output current to 50 % or stable condition between 50 and 100 %
< 5.0 kΩ	System is reducing output current to 25 % or stable condition between 25 and 100 %
< 4.3 kΩ	System is reducing output current to 12.5 % or stable condition between 12.5 and 100 %
> 7.0 kΩ	Output current is slowly reset to 100 %

Dimming

Dimming range 10 % to 100 % (absolute minimum 105 mA)

Control with

- Potentiometer
- 1 ... 10 V
- Output current range: 400 – 550 μA

1 ... 10 V function

The light intensity of the LEDs vary proportionally to the signal sent to the terminal.

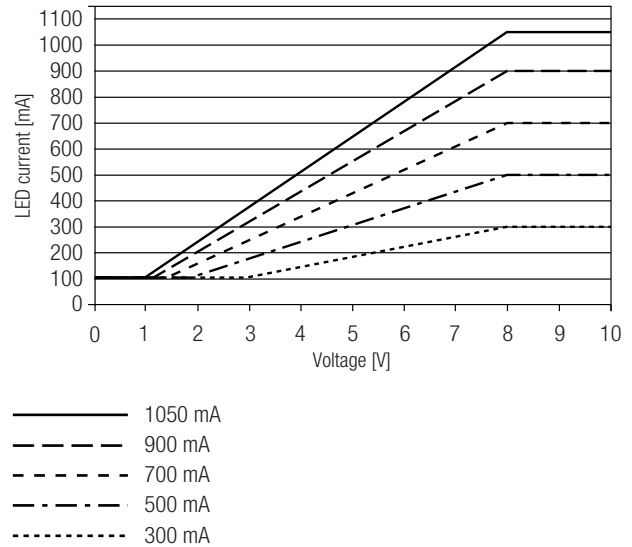

Function: adjustable current (I-select 2)

"I-select resistor 2"

Adjustable range	300 – 1,050 mA
------------------	----------------

By inserting a suitable resistor into the I-select 2 interface, the current value can be adjusted. The relationship between output current and resistor value can be found in the chapter "Accessories I-SELECT 2 Plugs". If the resistor is connected by wires, ensure a consistent base isolation. Furthermore, a max. wire length of 2 m may not be exceeded. Avoid potential interferences.



Please note that the resistor values for I-select 2 are not compatible with I-select (generation 1). Installation of an incorrect resistor may cause irreparable damage to the LED module(s).

Resistors for the main output current values can be ordered from Tridonic (see accessories).

$$I_{out} [A] = 5 V / R_{set} [\Omega] \times 1000$$

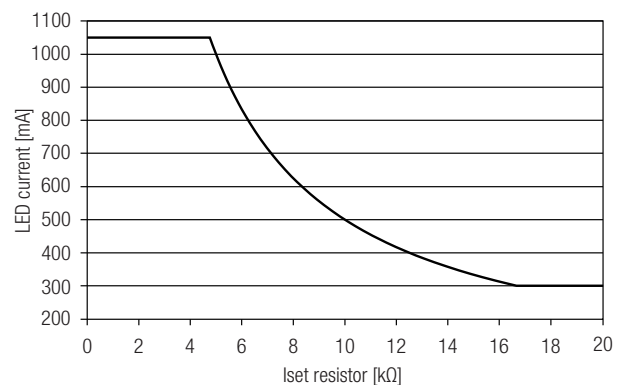

Humidity: 5 % up to max. 85 %, not condensed (max. 56 days/year at 85 %)

Storage temperature: -40 °C up to max. +80 °C

The devices have to be within the specified temperature range (ta) before they can be operated.

Expected life-time

Type	Output current	ta	40°C	50°C	55°C
LCA 120W 300-1050mA 1-10V C ADV OTD	300 – 500 mA	tc	60°C	70°C	75°C
		Life-time	>100,000 h	>100,000 h	>100,000 h
	> 500 – 1,050 mA	tc	70°C	80°C	85°C
		Life-time	>100,000 h	75,000 h	55,000 h

Maximum loading of automatic circuit breakers

Automatic circuit breaker type	B10	B13	B16	B20	C10	C13	C16	C20	Inrush current
Installation Ø	1.5 mm ²	1.5 mm ²	1.5 mm ²	2.5 mm ²	1.5 mm ²	1.5 mm ²	1.5 mm ²	2.5 mm ²	I _{max} Time
LCA 120W 300-1050mA 1-10V C ADV OTD	3	5	7	9	6	10	14	18	56 A 280 µs

Harmonic distortion in the mains supply (at 230 V / 50 Hz and full load) in %

Output current	THD	3.	5.	7.	9.	11.
300 mA	< 29	< 28	< 6	< 1	< 2	< 2
500 mA	< 17	< 15	< 6	< 4	< 2	< 1
LCA 120W 300-1050mA 1-10V C ADV OTD	700 mA	< 14	< 12	< 5	< 4	< 2
900 mA	< 12	< 5	< 3	< 2	< 2	< 2
1,050 mA	< 13	< 13	< 4	< 3	< 3	< 1

Installation instructions

The LED module and all contact points within the wiring must be sufficiently insulated against 2 kV surge voltage. Air and creepage distance must be maintained.

Replace LED module

1. Mains off
2. Remove LED module
3. Wait for 10 seconds
4. Connect LED module again

Hot plug-in or secondary switching of LEDs is not permitted and may cause a very high current to the LEDs.

Wiring type and cross section

The input wiring can be stranded wires with ferrules with a cross section of 0.5 – 1.5 mm² or with solid wires with a cross section of 0.5 – 2.5 mm². Strip 10 – 11 mm of insulation from the cables to ensure perfect operation of the push-wire terminals.

The output wiring can be done with a cross section of 0.2 – 1.5 mm². Strip 8.5 – 9.5 mm of insulation from the cables to ensure perfect operation of the push-wire terminals.

Input wiring

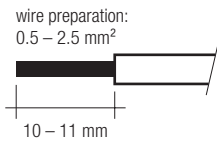

Output / interface wiring

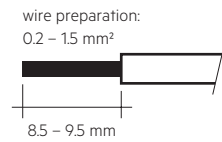

Release of the wiring

Press down the “push button” and remove the cable from front.

Input terminal

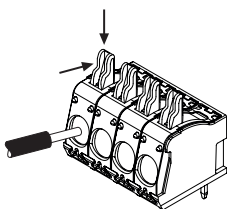

Output / interface terminal

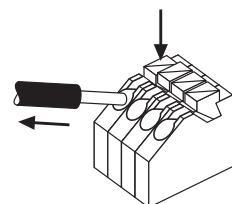

Wiring diagram

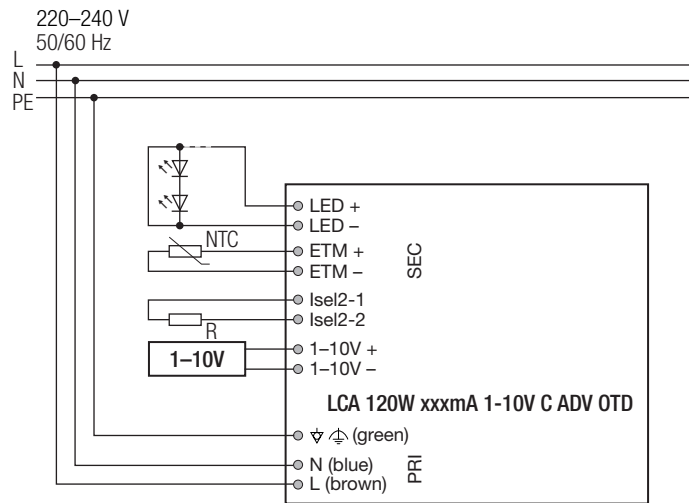

Wiring guidelines

- All connections must be kept as short as possible to ensure good EMI behaviour.
- Mains leads should be kept apart from LED Driver and other leads (ideally 5 – 10 cm distance)
- Max. length of output wires is 2 m.
- Secondary switching is not permitted.
- Incorrect wiring may damage LED modules.
- The wiring must be protected against short circuits to earth (sharp edged metal parts, metal cable clips, louver, etc.).

Insulation	Input wires	LED output / ITM	1 ... 10 V
Input wires	–	Double	Double
LED output / ITM	Double	–	Double
1 ... 10 V	Double	Double	–

Earth connection

The earth connection is conducted as function earth (FE). There is no earth connection required for the functionality of the LED Driver. Earth connection is recommended to improve following behaviour:

- Electromagnetic interferences (EMI)
- LED glowing at standby
- Transmission of mains transients to the LED output

External I-select 2 resistors on LED modules

LED modules with on-board I-select 2 resistors may cause irreparable damages, caused by surge / burst peaks.

Isolation and electric strength testing of luminaires

Electronic devices can be damaged by high voltage. This has to be considered during the routine testing of the luminaires in production.

According to IEC 60598-1 Annex Q (informative only!) or ENEC 303-Annex A, each luminaire should be submitted to an isolation test with 500 V_{DC} for 1 second. This test voltage should be connected between the interconnected phase and neutral terminals and the earth terminal. The isolation resistance must be at least 2 MΩ.

As an alternative, IEC 60598-1 Annex Q describes a test of the electrical strength with 1500 V_{AC} (or 1.414 x 1500 V_{DC}). To avoid damage to the electronic devices this test must not be conducted.

Additional information

Additional technical information at www.tridonic.com → Technical Data

Guarantee conditions at www.tridonic.com → Services

Life-time declarations are informative and represent no warranty claim. No warranty if device was opened.

Diagrams LCA 120W 300-1050mA 1-10V C ADV

Efficiency vs load

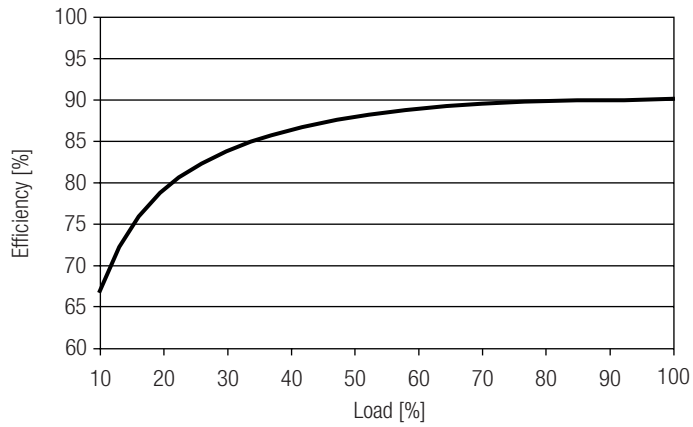

Power factor vs load

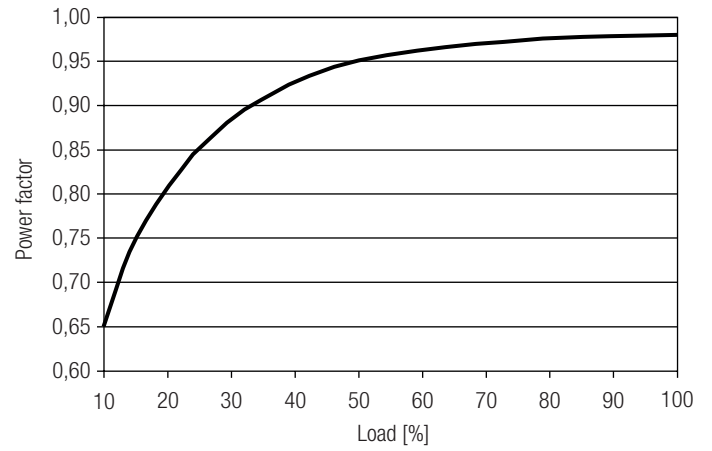

Input power vs load

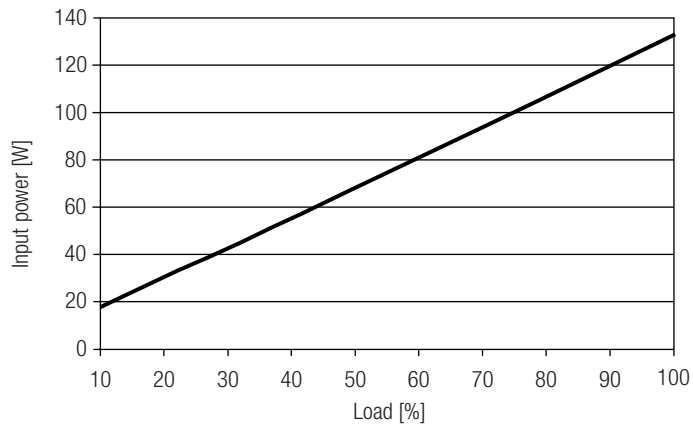

Input current vs load

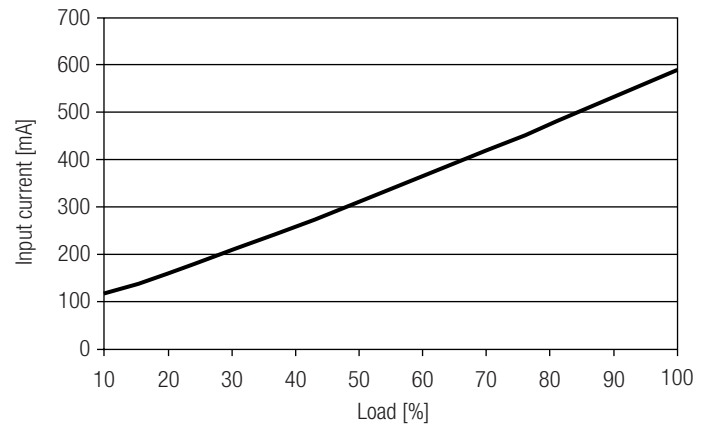

THD vs load

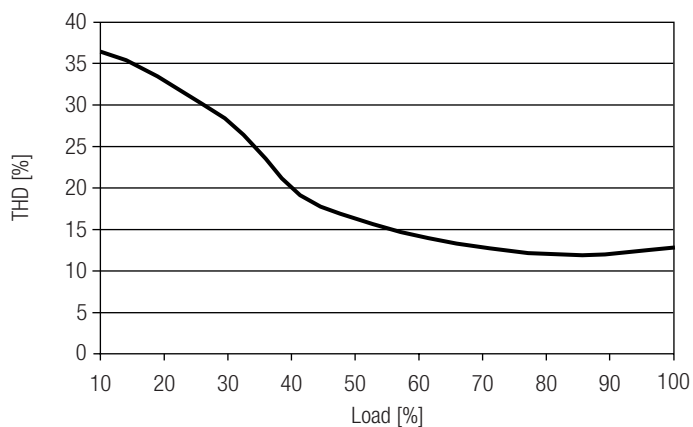

Output current	Load range
350 mA	10 – 29 %
500 mA	17 – 48 %
700 mA	23 – 68 %
900 mA	30 – 87 %
1,050 mA	35 – 100 %