

IP20 SELV     

Driver LCAI 35W 350mA–900mA ECO C flat

ECO series

Product description

- Dimmable built-in LED Driver for LED
- Constant current LED Driver
- Output current adjustable between 350 – 900 mA
- Max. output power 35 W
- Nominal life-time up to 100,000 h
- 5-year guarantee
- Dimming range 1 ... 100 %

Properties

- Compact low-profile dimensions
- Casing: polycarbonate, white
- Type of protection IP20

Interfaces

- DALI DEVICE Type 6
- DSI
- switchDIM (with memory function)
- corridorFUNCTION

Functions

- Adjustable output current (I-select resistor or DALI)
- Power-up fading at AC
- Intelligent Temperature Guard (overtemperature protection)
- Short-circuit proof
- Overload protection
- Constant Light Output function
- Suitable for emergency escape lighting systems acc. to EN50172

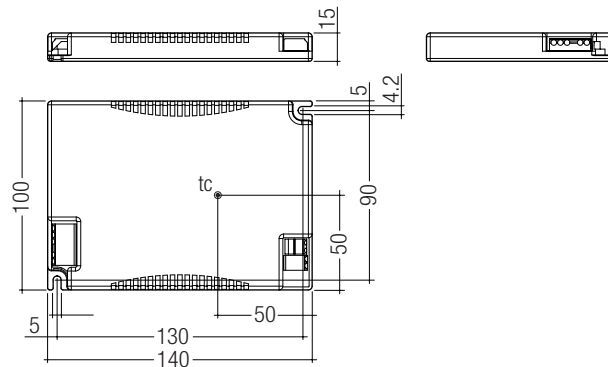

Ordering data

Type	Article number	Packaging carton	Packaging pallet	Weight per pc.
LCAI 35W 350mA-900mA ECO C flat	28000336	20 pc(s).	1,000 pc(s).	0.170 kg



Standards, page 4

Technical data

Rated supply voltage	220 – 240 V
AC voltage range	198 – 264 V
DC voltage range	170 – 280 V
Mains frequency	0 / 50 / 60 Hz
Overvoltage protection	320 V AC, 48 h
Typ. current (at 230 V, 50 Hz, full load) ^① ②	153 – 185 mA
Typ. current (220 V, 0 Hz, full load, 15 % dimming level) ^②	32 – 35 mA
Leakage current (PE)	< 0.22 mA
Max. input power	42.5 W
Typ. efficiency (at 230 V / 50 Hz / full load) ^②	86 – 89 %
λ (at 230 V, 50 Hz, full load) ^③	≥ 0.98
Typ. power input on stand-by ^③	75 – 100 mW
THD (at 230 V, 50 Hz, full load)	< 4.4 %
Time to light (at 230 V, 50 Hz, full load, acc. to DALI)	< 0.6 s
Time to light (DC mode)	< 0.2 s
Switchover time (AC/DC)	< 0.2 s
Turn off time (at 230 V, 50 Hz, full load)	< 20 ms
Hold on time (at 230 V, 50 Hz, full load) ^④	< 14 ms
Output current tolerance ^⑤ ⑥	± 5 %
Output LF current ripple (< 120 Hz)	< 2 %
Max. peak output current	≤ output current + 20 %
PWM frequency ^⑦	500 Hz
Dimming range	1 – 100 %
Max. output voltage	120 V
Burst / surge peaks output side against PE	1.2 kV
Dimensions L x W x H	140 x 100 x 15 mm

Specific technical data

Type	Output current ^⑧	Min. forward voltage	Max. forward voltage ^⑨	Max. output power ^⑩	Typ. power consumption (at 230 V, 50 Hz, full load)	Typ. current consumption (at 230 V, 50 Hz, full load)	Max. casing temperature tc	Ambient temperature ta max.	I-select resistor value
LCAI 35W 350mA-900mA ECO C flat	350 mA	40 V	90 V	31.5 W	34.7 W	153 mA	90 °C	-25 ... +60 °C	open
	375 mA	40 V	90 V	33.8 W	37.4 W	165 mA	90 °C	-25 ... +60 °C	71.50 kΩ
	400 mA	39 V	88 V	35.2 W	39.5 W	174 mA	90 °C	-25 ... +60 °C	66.50 kΩ
	425 mA	37 V	83 V	35.3 W	40.0 W	176 mA	90 °C	-25 ... +60 °C	61.90 kΩ
	450 mA	35 V	79 V	35.6 W	40.4 W	177 mA	90 °C	-25 ... +60 °C	57.60 kΩ
	475 mA	33 V	75 V	35.6 W	40.4 W	178 mA	90 °C	-25 ... +60 °C	53.60 kΩ
	500 mA	31 V	71 V	35.5 W	40.5 W	178 mA	90 °C	-25 ... +60 °C	49.90 kΩ
	525 mA	30 V	68 V	35.7 W	40.6 W	178 mA	90 °C	-25 ... +60 °C	45.30 kΩ
	550 mA	28 V	65 V	35.8 W	40.8 W	179 mA	90 °C	-25 ... +60 °C	42.20 kΩ
	575 mA	27 V	62 V	35.7 W	40.8 W	179 mA	90 °C	-25 ... +60 °C	38.30 kΩ
	600 mA	26 V	59 V	35.4 W	40.6 W	178 mA	90 °C	-25 ... +60 °C	35.70 kΩ
	625 mA	25 V	57 V	35.6 W	40.9 W	180 mA	90 °C	-25 ... +60 °C	32.40 kΩ
	650 mA	24 V	55 V	35.8 W	41.0 W	180 mA	90 °C	-25 ... +60 °C	28.70 kΩ
	675 mA	23 V	53 V	35.8 W	41.2 W	181 mA	90 °C	-25 ... +60 °C	26.10 kΩ
	700 mA	22 V	51 V	35.7 W	41.4 W	182 mA	90 °C	-25 ... +60 °C	22.00 kΩ
	725 mA	21 V	49 V	35.5 W	41.1 W	181 mA	90 °C	-25 ... +55 °C	17.40 kΩ
	750 mA	21 V	47 V	35.3 W	40.9 W	180 mA	90 °C	-25 ... +55 °C	15.00 kΩ
	775 mA	20 V	46 V	35.7 W	41.5 W	182 mA	90 °C	-25 ... +55 °C	12.40 kΩ
	800 mA	19 V	44 V	35.2 W	41.3 W	181 mA	90 °C	-25 ... +55 °C	10.00 kΩ
	825 mA	19 V	43 V	35.5 W	41.5 W	182 mA	90 °C	-25 ... +55 °C	7.68 kΩ
850 mA	18 V	42 V	35.7 W	41.8 W	184 mA	90 °C	-25 ... +55 °C	5.36 kΩ	
875 mA	17 V	41 V	35.9 W	42.1 W	185 mA	90 °C	-25 ... +55 °C	3.16 kΩ	
900 mA	17 V	39 V	35.1 W	41.3 W	182 mA	90 °C	-25 ... +55 °C	short circuit (0 Ω)	

① Valid at 100 % dimming level.

② Depending on the selected output current.

③ Depending on the DALI traffic at the interface.

④ At power failure.

⑤ ± 20 %.

⑥ At full load.

⑦ Output current is mean value.

Product description

- Ready-for-use resistor to set output current value
- Compatible with LED Driver series TOP and ECO
- Resistor is base isolated
- Resistor power 0.25 W
- Resistor value tolerance $\pm 1\%$

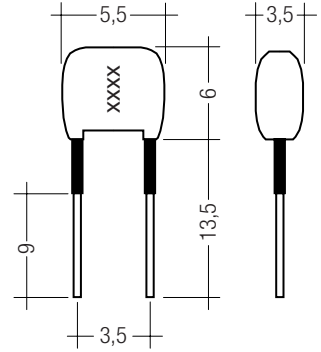
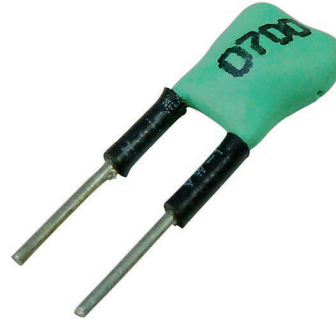

Ordering data

Type	Article number	Colour	Marking	Resistor value	Packaging bag	Weight per pc.
I-SELECT PLUG 400mA GN	28000451	Green	0400	66.50 k Ω	10 pc(s).	0.001 kg
I-SELECT PLUG 450mA GN	28000452	Green	0450	57.60 k Ω	10 pc(s).	0.001 kg
I-SELECT PLUG 500mA GN	28000277	Green	0500	49.90 k Ω	10 pc(s).	0.001 kg
I-SELECT PLUG 550mA GN	28000453	Green	0550	42.20 k Ω	10 pc(s).	0.001 kg
I-SELECT PLUG 600mA GN	28000454	Green	0600	35.70 k Ω	10 pc(s).	0.001 kg
I-SELECT PLUG 650mA GN	28000455	Green	0650	28.70 k Ω	10 pc(s).	0.001 kg
I-SELECT PLUG 700mA GN	28000278	Green	0700	22.00 k Ω	10 pc(s).	0.001 kg
I-SELECT PLUG 750mA GN	28000456	Green	0750	15.00 k Ω	10 pc(s).	0.001 kg
I-SELECT PLUG 800mA GN	28000457	Green	0800	10.00 k Ω	10 pc(s).	0.001 kg
I-SELECT PLUG 850mA GN	28000458	Green	0850	5.36 k Ω	10 pc(s).	0.001 kg
I-SELECT PLUG MAX GR	28000274	Grey	MAX	0 Ω	10 pc(s).	0.001 kg

Standards

EN 55015
 EN 61000-3-2
 EN 61000-3-3
 EN 61347-1
 EN 61347-2-13
 EN 62384
 EN 61547
 EN 62386-101 (according to DALI standard V1)
 EN 62386-102
 EN 62386-207
 According to EN 50172 for use in central battery systems
 According to EN 60598-2-22 suitable for emergency lighting installations

Housing fulfils requirements for reinforced insulation according EN 60598-1.

Overload protection

If the output voltage range is exceeded the LED Driver turns off the LED output. After restart of the LED Driver the output will be activated again. The restart can either be done via mains reset or via interface (DALI, DSI, switchDIM).

Overtemperature protection

The LED Driver is protected against temporary thermal overheating. If the temperature limit is exceeded the output current of the LED is reduced. The temperature protection is activated approx. +5 °C above t_c max (see page 2). On DC operation this function is deactivated to fulfill emergency requirements.

Short-circuit behaviour

In case of a short circuit at the LED output the LED output is switched off. After restart of the LED Driver the output will be activated again. The restart can either be done via mains reset or via interface (DALI, DSI, switchDIM).

No-load operation

The LED Driver will not be damaged in the no-load operation. The output will be deactivated and therefore free of voltage. If a LED load is connected the device has to be restarted before the output will be activated again.

Expected life-time

Type	Output current	t_a	40 °C	45 °C	50 °C	55 °C	60 °C
	350 mA	t_c	65 °C	70 °C	75 °C	80 °C	80 °C
		Life-time	> 100,000 h	> 100,000 h	> 100,000 h	> 100,000 h	80,000 h
LCAI 35W 350mA-900mA ECO C flat	≤ 700 mA	t_c	75 °C	80 °C	80 °C	85 °C	90 °C
		Life-time	> 100,000 h	> 100,000 h	95,000 h	70,000 h	50,000 h
	≤ 900 mA	t_c	75 °C	80 °C	85 °C	90 °C	90 °C
		Life-time	> 100,000 h	> 100,000 h	80,000 h	55,000 h	-

The LED Driver is designed for a life-time stated above under reference conditions and with a failure probability of less than 10 %.

Maximum loading of automatic circuit breakers

Automatic circuit breaker type	C10	C13	C16	C20	B10	B13	B16	B20	Inrush current
Installation Ø	1.5 mm ²	1.5 mm ²	2.5 mm ²	4 mm ²	1.5 mm ²	1.5 mm ²	2.5 mm ²	4 mm ²	I_{max} time
LCAI 35W 350mA-900mA ECO C flat	32	50	56	66	16	25	28	33	3.4 A 358 µs

Harmonic distortion in the mains supply (at 230 V / 50 Hz and full load) in %

	THD	3.	5.	7.	9.	11.
LCAI 35W 350mA-900mA ECO C flat	< 4.4	4.4	< 1	< 1	< 1	< 1

Hot plug-in

Hot plug-in is not recommend within 5 s after shutdown due to output voltage of > 0 V. If a LED load is connected the device has to be restarted before the output will be activated again. This can be done with mains reset, DALI, DSI or switchDIM.

Conditions of use and storage

Humidity: 5 % up to max. 85 %, not condensed (max. 56 days/year at 85 %)

Storage temperature: -40 °C up to max. +80 °C

The devices have to be within the specified temperature range (t_a) before they can be operated.

Glow wire test

according to EN 61347-1 with increased temperature of 850 °C passed.

Control input (DA/N, DA/L)

Digital DALI signal or switchDIM can be wired on the same terminals (DA/N and DA/L).

Digital signal DALI/DSI

The control input is non-polar for digital control signals (DALI, DSI). The control signal is not SELV. Control cable has to be installed in accordance to the requirements of low voltage installations.

Different functions depending on each module.

switchDIM

Integrated switchDIM function allows a direct connection of a push to make switch for dimming and switching.

Brief push (< 0.6 s) switches LED Driver ON and OFF. The LED Drivers switch-ON at light level set at switch-OFF.

When the push to make switch is held, LED modules are dimmed. After repush the LED modules are dimmed in the opposite direction.

In installations with LED Drivers with different dimming levels or opposite dimming directions (e.g. after a system extension), all LED Drivers can be synchronized to 50 % dimming level by a 10 s push.

Use of push to make switch with indicator lamp is not permitted.

corridorFUNCTION

The corridorFUNCTION can be programmed in two different ways.

To program the corridorFUNCTION by means of software a DALI-USB interface is needed in combination with a DALI PS. The software can be the masterCONFIGURATOR.

To activate the corridorFUNCTION without using software a voltage of 230 V simply has to be applied for five minutes at the switchDIM connection.

The unit will then switch automatically to the corridorFUNCTION.

Note:

If the corridorFUNCTION is wrongly activated in a switchDIM system (for example a switch is used instead of pushbutton), there is the option of installing a pushbutton and deactivating the corridorFUNCTION mode by five short pushes of the button within three seconds.

switchDIM and corridorFUNCTION are very simple tools for controlling ballasts with conventional momentary-action switches or motion sensors. To ensure correct operation a sinusoidal mains voltage with a frequency of 50 Hz or 60 Hz is required at the control input.

Special attention must be paid to achieving clear zero crossings. Serious mains faults may impair the operation of switchDIM and corridorFUNCTION.

Function: adjustable current (I-select)

The output current of the LED Driver can be selected between 350 and 900 mA via DALI.

Adjustment can be done by masterCONFIGURATOR (see masterCONFIGURATOR documentation).

Constant light output (CLO)

The luminous flux of an LED decreases constantly over the life-time. The CLO function ensures that the emitted luminous flux remains stable. For that purpose the LED current will increase continuously over the LED life-time.

In masterCONFIGURATOR it is possible to select a start value (in percent) and an expected life-time. The LED Driver adjusts the current afterwards automatically.

Dimming

Dimming range 1 % to 100 %

Digital control with:

- DSI signal: 8 bit Manchester Code
Speed 1 % to 100 % in 1.4 s
- DALI signal: 16 bit Manchester Code
Speed 1 % to 100 % in 0.2 s
Programmable parameter:
Minimum dimming level
Maximum dimming level
Default minimum = 1 %
Programmable range $1\% \leq \text{MIN} \leq 100\%$
Default maximum = 100 %
Programmable range $100\% \geq \text{MAX} \geq 1\%$

Dimming curve is adapted to the eye sensitiveness.

Dimming is realized by a combination of analog amplitude dimming and PWM dimming.

35 ... 100 %: amplitude dimming

1 ... 34 %: PWM dimming

Dimming characteristics

Digital dimming value

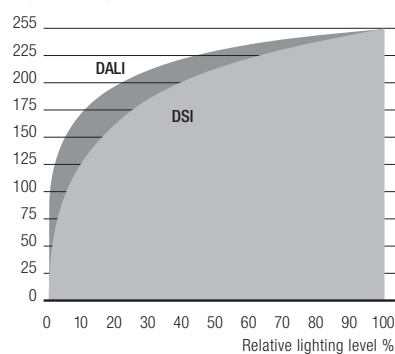

Dimming characteristics as seen by the human eye

DC emergency operation

The LED Driver is designed for operation on DC voltage and pulsed DC voltage.

Light output level in DC operation: programmable 1 – 100 % (EOF_x = 0.13). Programming by extended DSI or DALI signal (16 bit).

Default value is 15 %

In DC operation dimming mode can be activated.

The voltage-dependent input current of Driver incl. LED module is depending on the used load.

The voltage-dependent no-load current of Driver (without or defect LED module) is for:

AC: 20.5 mA

DC: 5.5 mA

Power-up fading

The power-up fading function offers the opportunity to realise a soft start. The soft start will be applied at turning on the mains and at starts by switchDIM.

The function is programmed as a DALI fade time in the range from 0.7 to 16 seconds and dims in the selected time from 0 % to the power-on level. By factory default power-up fading is not active (0 seconds).

Programming

With appropriate software and a USB interface different functions can be activated and various parameters can be configured in the LED Driver. All that is needed is a DALI-USB and the software (masterCONFIGURATOR).

masterCONFIGURATOR

At version 2.8:

For programming functions (CLO, I-SET, ITM, power-up fading, corridorFUNCTION) and device settings (fade time, ePowerOnLevel, DC level, etc.). For further information see masterCONFIGURATOR manual.

Electrical connections

Wiring

LED Driver / supply

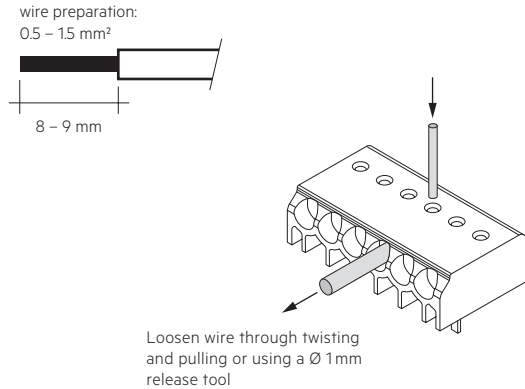

Wiring type and cross section

Solid wire with a cross section of 0.5 – 1.5 mm². Strip 8 – 9 mm of insulation from the cables to ensure perfect operation of terminals.

LED Driver / LED module

Wiring type and cross section

The wiring can be solid or flexible cable with a cross section of 0.2 to 0.75 mm². For the push-wire connection you have to strip the insulation (6–7 mm). Loosen wire through twisting and pulling.



Release of the wiring

Press down the “push button” and remove the cable from front.

Earth connection

The earth connection is conducted as protection earth (PE). If the LED Driver will be earthed, protection earth (PE) has to be used. There is no earth connection required for the functionality of the LED Driver. Earth connection is recommended to improve following behaviour.

- Electromagnetic interferences (EMI)
- LED glowing at stand-by
- Transmission of mains transients to the LED output

In general it is recommended to earth the LED Driver if the LED module is mounted on earthed luminaire parts respectively heat sinks and thereby representing a high capacity against earth.

Installation note

Max. torque at the clamping screw: 0.5 Nm / M4

Circuit diagram

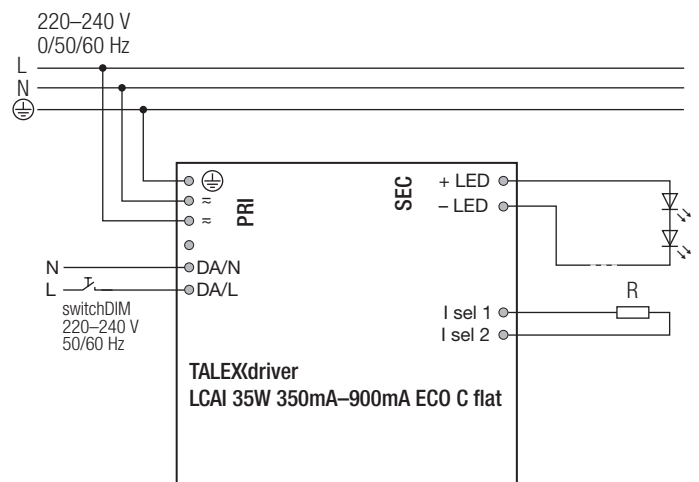
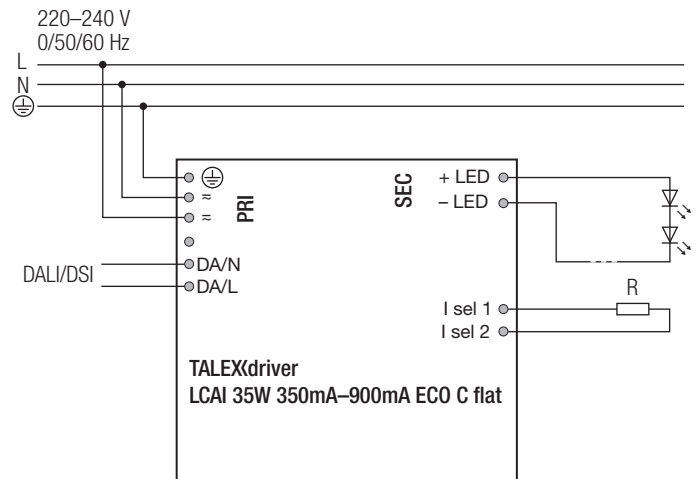

Wiring guidelines

- The cables should be run separately from the mains connections and mains cables to ensure good EMC conditions.
- The LED wiring should be kept as short as possible to ensure good EMC. The max. secondary cable length is 2 m (4 m circuit), this applies for LED output as well as for I-SET and temperature sensor.
- Secondary switching is not permitted.
- The LED Driver has no inverse-polarity protection on the secondary side. Wrong polarity can damage LED modules with no inverse-polarity protection.

Isolation and electric strength testing of luminaires

Electronic devices can be damaged by high voltage. This has to be considered during the routine testing of the luminaires in production.

According to IEC 60598-1 Annex Q (informative only!) or ENEC 303-Annex A, each luminaire should be submitted to an isolation test with 500 V_{DC} for 1 second. This test voltage should be connected between the interconnected phase and neutral terminals and the earth terminal. The isolation resistance must be at least 2 MΩ.

As an alternative, IEC 60598-1 Annex Q describes a test of the electrical strength with 1500 V_{AC} (or 1.414 x 1500 V_{DC}). To avoid damage to the electronic devices this test must not be conducted.

Diagrams LCAI 35W 350mA-900mA ECO C flat

Efficiency vs load

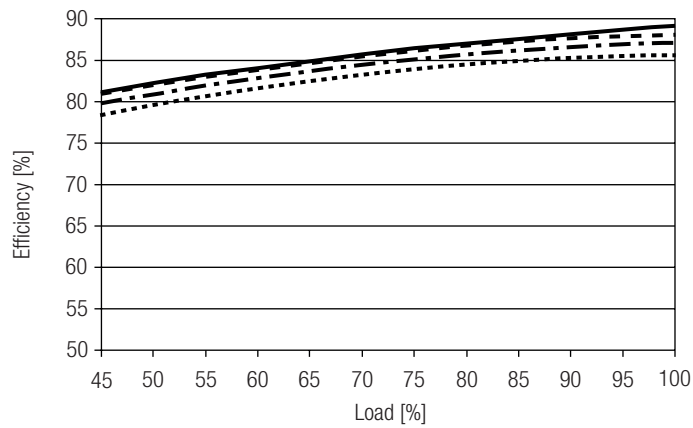

Power factor vs load

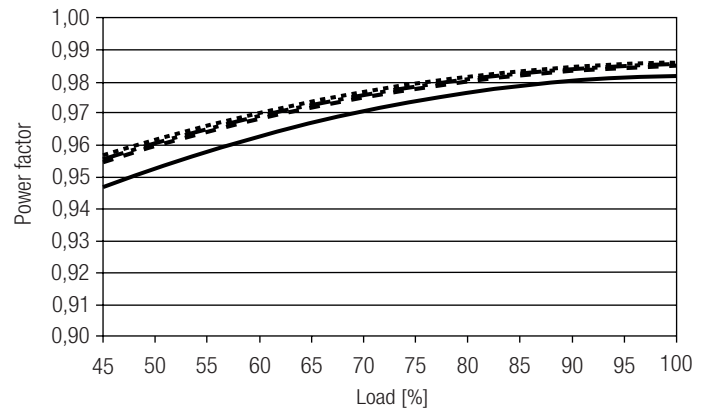

THD vs load

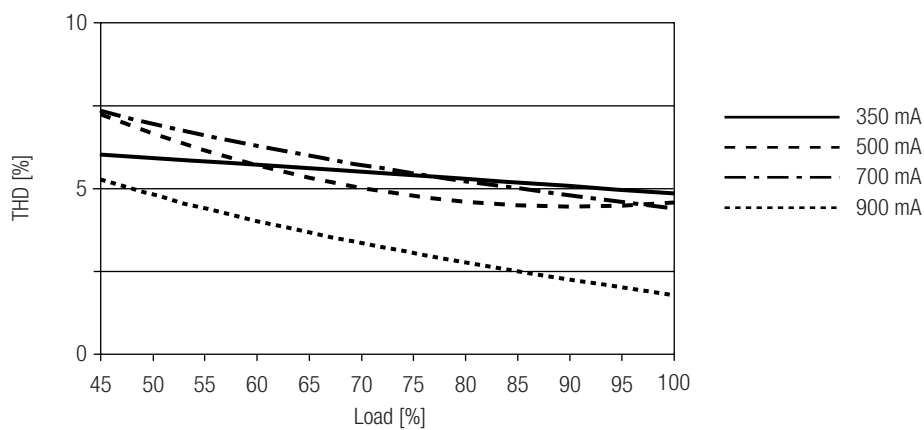

100 % load correspond to the max. output power (full load) according to the table on page 2.

Additional information

Additional technical information at www.tridonic.com → Technical Data

Guarantee conditions at www.tridonic.com → Services

Life-time declarations are informative and represent no warranty claim.
No warranty if device was opened.