

IP20 SELV      

### Driver LCI 10W 350mA-900mA TOP C

TOP series

#### Product description

- Fixed output built-in LED Driver
- Constant current LED Driver
- Output current settable 350 – 900 mA
- Max. output power 10 W
- Nominal life-time up to 100,000 h
- For luminaires of protection class I and protection class II
- Temperature protection as per EN 61347-2-13 C5e
- 5-year guarantee

#### Properties

- Casing: polycarbonate, white
- Type of protection IP20

#### Functions

- Intelligent Temperature Guard (overtemperature protection)
- Short-circuit proof
- Overload protection
- Suitable for emergency escape lighting systems acc. to EN 50172

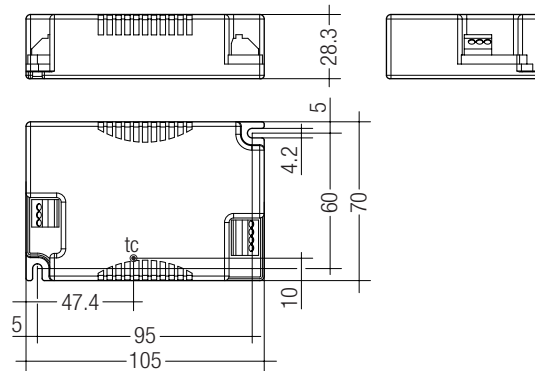

#### Ordering data

Type	Article number	Packaging carton	Packaging pallet	Weight per pc.
LCI 10W 350mA-900mA TOP C	28000190	10 pc(s).	960 pc(s).	0.115 kg



Standards, page 4

**Technical data**

Rated supply voltage	220 – 240 V
AC voltage range	198 – 264 V
DC voltage range	176 – 280 V (start ≥ 198 V DC)
Mains frequency	0 / 50 / 60 Hz
Overvoltage protection	320 V AC, 48 h
Leakage current (PE)	< 0.5 mA
Max. input power	13.1 W
Efficiency (at 230 V, 50 Hz, full load)	76 – 82 %
THD (at 230 V, 50 Hz, full load)	< 15 %
Output current tolerance	± 5 %
Output LF current ripple (< 300 Hz)	< 2 %
Max. peak output current	Output current + 20 %
Max. output voltage (no-load voltage)	60 V
Time to light (at 230 V, 50 Hz, full load)	< 0.5 s
Time to light (DC mode)	< 0.5 s
Hold on time at power failure or switch-off	< 0.5 s
Switchover time (AC/DC)	< 0.5 s
Burst / surge peaks output side against PE	2 kV
Dimensions L x W x H	105 x 70 x 28.3 mm

**Specific technical data**

Type	Output current	Min. output voltage	Max. output voltage	Max. output power	Input power (at 230 V, 50 Hz, full load)	Input current (at 230 V, 50 Hz, full load)	λ (at 230 V, 50 Hz, full load)	tc point	Ambient temperature ta	tc/ta for ≥ 50.000 h	I sel resistor value
<b>LCI 10W 350mA-900mA TOP C</b>	350 mA	12.9 V	28.6 V	10.0 W	12.2 W	59 mA	0.90	75 °C	-25 ... +65 °C	75 / 65 °C	open circuit
	400 mA	11.3 V	25.0 V	10.0 W	12.3 W	59 mA	0.90	75 °C	-25 ... +65 °C	75 / 65 °C	66.50 kΩ
	450 mA	10.0 V	22.2 V	10.0 W	12.3 W	59 mA	0.90	75 °C	-25 ... +65 °C	75 / 65 °C	57.60 kΩ
	500 mA	9.0 V	20.0 V	10.0 W	12.4 W	60 mA	0.90	75 °C	-25 ... +65 °C	75 / 65 °C	49.90 kΩ
	550 mA	8.2 V	18.2 V	10.0 W	12.4 W	60 mA	0.90	75 °C	-25 ... +65 °C	75 / 65 °C	42.20 kΩ
	600 mA	7.5 V	16.7 V	10.0 W	12.5 W	60 mA	0.90	75 °C	-25 ... +65 °C	75 / 65 °C	35.70 kΩ
	650 mA	6.9 V	15.4 V	10.0 W	12.6 W	61 mA	0.90	75 °C	-25 ... +65 °C	75 / 65 °C	28.70 kΩ
	700 mA	6.4 V	14.3 V	10.0 W	12.7 W	61 mA	0.90	75 °C	-25 ... +65 °C	75 / 65 °C	22.00 kΩ
	750 mA	6.0 V	13.3 V	10.0 W	12.8 W	62 mA	0.90	70 °C	-25 ... +60 °C	70 / 60 °C	15.00 kΩ
	800 mA	5.6 V	12.5 V	10.0 W	12.9 W	62 mA	0.90	70 °C	-25 ... +60 °C	70 / 60 °C	10.00 kΩ
	850 mA	5.3 V	11.8 V	10.0 W	13.0 W	63 mA	0.90	70 °C	-25 ... +60 °C	70 / 60 °C	5.36 kΩ
	900 mA	5.0 V	11.1 V	10.0 W	13.1 W	63 mA	0.91	70 °C	-25 ... +60 °C	70 / 60 °C	short circuit

**Product description**

- Ready-for-use resistor to set output current value
- Compatible with LED Driver series TOP and ECO
- Resistor is base isolated
- Resistor power 0.25 W
- Resistor value tolerance  $\pm 1\%$

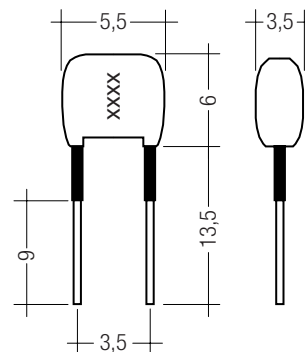
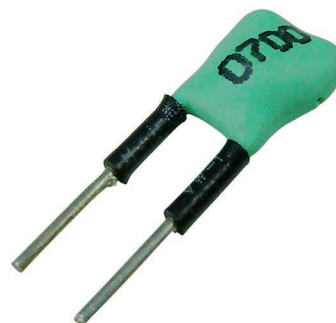

**Ordering data**

Type	Article number	Colour	Marking	Resistor value	Packaging bag	Weight per pc.
I-SELECT PLUG 400mA GN	28000451	Green	0400	66.50 k $\Omega$	10 pc(s).	0.001 kg
I-SELECT PLUG 450mA GN	28000452	Green	0450	57.60 k $\Omega$	10 pc(s).	0.001 kg
I-SELECT PLUG 500mA GN	28000277	Green	0500	49.90 k $\Omega$	10 pc(s).	0.001 kg
I-SELECT PLUG 550mA GN	28000453	Green	0550	42.20 k $\Omega$	10 pc(s).	0.001 kg
I-SELECT PLUG 600mA GN	28000454	Green	0600	35.70 k $\Omega$	10 pc(s).	0.001 kg
I-SELECT PLUG 650mA GN	28000455	Green	0650	28.70 k $\Omega$	10 pc(s).	0.001 kg
I-SELECT PLUG 700mA GN	28000278	Green	0700	22.00 k $\Omega$	10 pc(s).	0.001 kg
I-SELECT PLUG 750mA GN	28000456	Green	0750	15.00 k $\Omega$	10 pc(s).	0.001 kg
I-SELECT PLUG 800mA GN	28000457	Green	0800	10.00 k $\Omega$	10 pc(s).	0.001 kg
I-SELECT PLUG 850mA GN	28000458	Green	0850	5.36 k $\Omega$	10 pc(s).	0.001 kg
I-SELECT PLUG MAX GR	28000274	Grey	MAX	0 $\Omega$	10 pc(s).	0.001 kg

**Standards**

EN 55015  
EN 61000-3-2  
EN 61000-3-3  
EN 61347-2-13  
EN 62384  
EN 61547  
According to EN 50172 for use in central battery systems  
According to EN 60598-2-22 suitable for emergency lighting installations

Housing fulfils requirements for reinforced insulation according EN 60598-1.

**Output current setting**

Output current can be set by connecting a resistor between the 2 "I sel" terminals. Relationship between output current and resistor value can be found at the table "Specific technical data". Resistor values specified from standardised resistor value ranges.  
Resistor value tolerance has to be  $\leq 1\%$ .  
Resistor power has to be  $\geq 0.1$  W.  
If the resistor is connected with wires a max. wire length of 2 m may not be exceeded and possible interferences have to be avoided.  
Resistor detection at each start.  
Change of the resistor value during the operation will be not considered.  
Resistors for the main output current values can be ordered from Tridonic (see accessories).

**DC emergency operation**

The LED Driver is designed for operation on DC voltage and pulsed DC voltage.

Light output level in DC operation (EOF<sub>x</sub>): 100 % (cannot be adjusted)

The voltage-dependent input current of Driver incl. LED module is depending on the used load.

The voltage-dependent no-load current of Driver (without or defect LED module) is for:  
AC: < 24 mA  
DC: < 7 mA

**Overload protection**

LED Driver will switch off at overload operation. Mains reset is required to restart the LED Driver.

**Underload operation**

LED Driver will switch off at underload operation. Mains reset is required to restart the LED Driver.

**Expected life-time**

Type	Output current	ta	40 °C	50 °C	60 °C	65 °C
<b>LCI 10W 350mA-900mA TOP C</b>	350 – 700 mA	tc	49 °C	59 °C	69 °C	75 °C
		Life-time	> 100,000 h	100,000 h	75,000 h	50,000 h
	750 – 900 mA	tc	50 °C	60 °C	70 °C	x
		Life-time	> 100,000 h	75,000 h	50,000 h	x

x = nicht zulässig

The LED Driver is designed for a life-time stated above under reference conditions and with a failure probability of less than 10 %.

**Maximum loading of automatic circuit breakers**

Automatic circuit breaker type	C10	C13	C16	C20	B10	B13	B16	B20	Inrush current
Installation Ø	1,5 mm <sup>2</sup>	1,5 mm <sup>2</sup>	2,5 mm <sup>2</sup>	2,5 mm <sup>2</sup>	1,5 mm <sup>2</sup>	1,5 mm <sup>2</sup>	2,5 mm <sup>2</sup>	2,5 mm <sup>2</sup>	I <sub>max</sub> time
<b>LCI 10W 350mA-900mA TOP C</b>	110	140	170	220	110	140	170	220	6 A 20 µs

**Harmonic distortion in the mains supply (at 230 V / 50 Hz and full load) in %**

	THD	3.	5.	7.	9.	11.
<b>LCI 10W 350mA-900mA TOP C</b>	11	8	2	2	1	1

**Overtemperature protection**

The LED Driver will reduce output current at temporary thermal over-heating (exceeding max. tc point).  
On DC operation this function is deactivated to fulfill emergency requirements.

**Short-circuit behaviour**

LED Driver will switch off in case of short-circuit of LED output. Mains reset is required to restart the LED Driver.

**No-load operation or load loss during operation**

LED Driver will detect a load loss during operation. In this case and no-load operation the max. output voltage can apply at the LED output for max. 5 s before LED Driver shuts down. Mains reset is required to restart the LED Driver.

**Hot plug-in**

Hot plug-in is not recommend within 5 s after shutdown due to output voltage of > 0 V. Mains reset is required to restart the LED Driver if LED module is connected to the LED Driver after these 5 s.

**Conditions of use and storage**

Humidity: 5 % up to max. 85 %, not condensed (max. 56 days/year at 85 %)

Storage temperature: -40 °C up to max. +80 °C

The devices have to be within the specified temperature range (ta) before they can be operated.

**Glow-wire test**

according to EN 61347-1 with increased temperature of 960 °C passed.

**Temperature range**

The LED Driver life duration is related to the ambient temperature ta. The relation of tc to ta temperature depends also on the luminaire design. If the measured tc temperature is approx. 5 K below tc max. or higher, ta temperature should be checked and eventually critical components (e.g. ELCAP) measured.  
Detailed information on request.

## Installation instructions

### Wiring type and cross section

The wiring can be in stranded wires with ferrules or solid with a cross section of 0.5–1.5 mm<sup>2</sup> for mains wires and 0.2–1.5 mm<sup>2</sup> for secondary wires.

Strip 9.5 mm of insulation from the cables to ensure perfect operation of the push-wire terminals.

Use one wire for each terminal connector only.

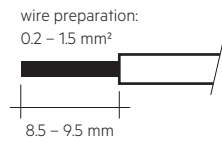

### Release of the wiring

Press down the “push button” and remove the cable from front.

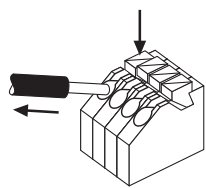

### Mounting of device

Max. torque for fixing: 0.5 Nm/M4

### Wiring guidelines

- All connections must be kept as short as possible to ensure good EMI behaviour.
- Earthing is not required for the device to operate but will improve the EMI behaviour.
- If LCI TOP C will be earthed protection earth (PE) has to be used.
- Mains leads should be kept apart from LED Driver and other leads (ideally 5 – 10 cm distance)
- Max. length of output and I sel wires is 2 m.
- Secondary switching is not permitted.
- Incorrect wiring can damage LED modules.
- The wiring must be protected against short circuits to earth (sharp edged metal parts, metal cable clips, louver, etc.).

### Earth connection

The earth connection is conducted as protection earth (PE). If the LED driver will be earthed, protection earth (PE) has to be used. There is no earth connection required for the functionality of the LED Driver.

Earth connection is recommended to improve following behaviour.

- Electromagnetic interferences (EMI)
- Transmission of mains transients to the LED output

In general it is recommended to earth the LED Driver if the LED module is mounted on earthed luminaire parts respectively heat sinks and thereby representing a high capacity against earth.

## Circuit diagram

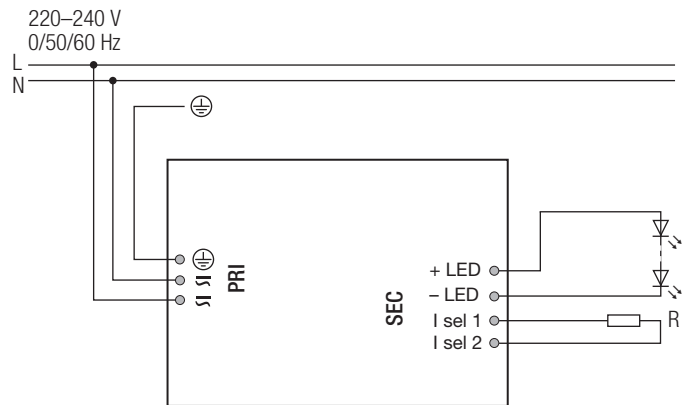

### Isolation and electric strength testing of luminaires

Electronic devices can be damaged by high voltage. This has to be considered during the routine testing of the luminaires in production.

According to IEC 60598-1 Annex Q (informative only!) or ENEC 303-Annex A, each luminaire should be submitted to an isolation test with 500 V<sub>DC</sub> for 1 second. This test voltage should be connected between the interconnected phase and neutral terminals and the earth terminal.

The isolation resistance must be at least 2 MΩ.

As an alternative, IEC 60598-1 Annex Q describes a test of the electrical strength with 1500 V<sub>AC</sub> (or 1.414 x 1500 V<sub>DC</sub>). To avoid damage to the electronic devices this test must not be conducted.

### Additional information

Additional technical information at [www.tridonic.com](http://www.tridonic.com) → Technical Data

Guarantee conditions at [www.tridonic.com](http://www.tridonic.com) → Services

Life-time declarations are informative and represent no warranty claim. No warranty if device was opened.

**Diagrams LCI 10W 350mA-900mA TOP C**

Efficiency vs load

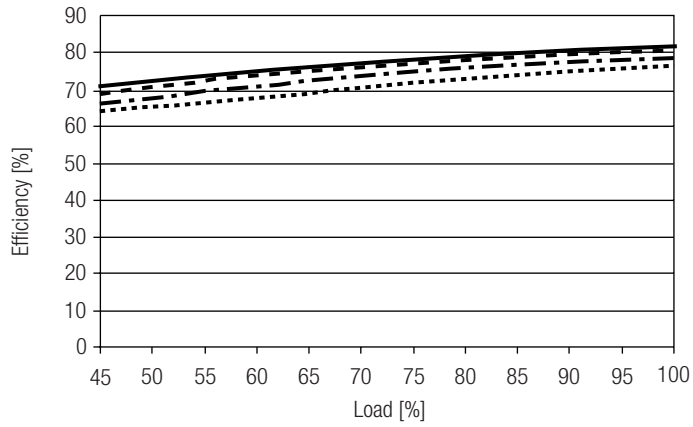

Power factor vs load

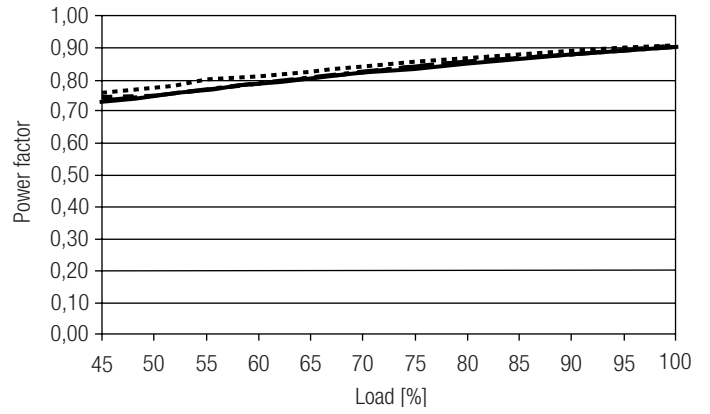

Input power vs load

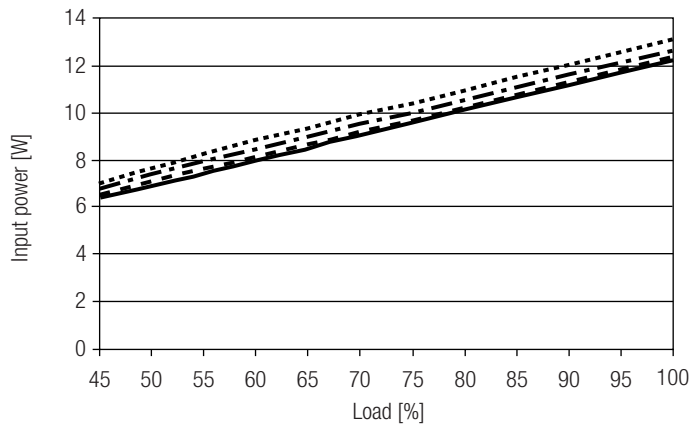

Input current vs load

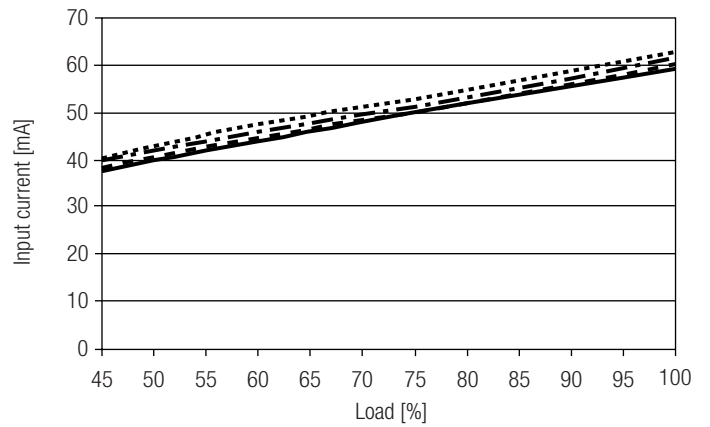

THD vs load

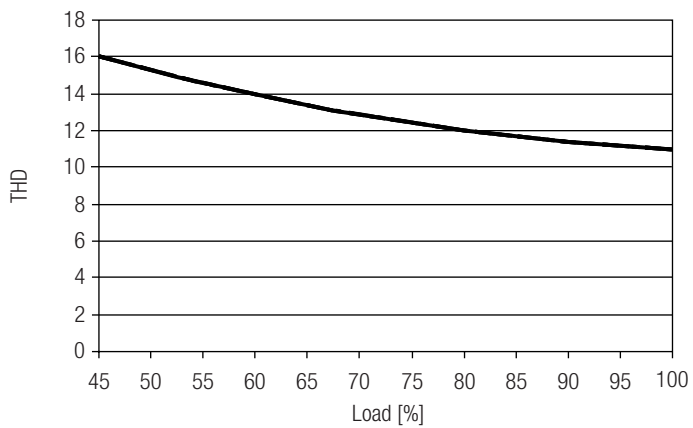

- 350 mA
- - - 500 mA
- · - · 700 mA
- · · · 900 mA