



DALI x/e-touchPANEL 02

Lighting and emergency lighting control system

Product description

DALI control system with 2 mode options:

- Lighting management in mains mode
- Emergency lighting management

Properties

- Colour touch screen 7"
- Background lighting with RGB LEDs
- User-friendly application software
- With DALI system functions of addressing and grouping
- USB and ethernet interface
- Can be remote-controlled via standard internet browser or software em-LINK (available at www.tridonic.com)
- Up-/downloading of the emergency lighting test report and firmware via USB or Ethernet
- 5-year guarantee

Lighting management

- Lighting management system with up to 128 DALI devices
- Start-up, control and operating unit
- Manual dimming and switching
- Manual scene recall or timed scene recall with a maximum of 99 sequences
- Tunable white (colour converter) control (colour temperature along the Planckian Locus)
- Weekday-controlled sequence programming (schedule)
- User-defined labelling of scenes, groups, sequences and schedules
- Optimised mode for RGB coloured lighting management

Emergency lighting management

- For small and medium emergency lighting systems with up to 120 DALI emergency lighting units (60 for each DALI line) per DALI x/e-touchPANEL 02
- 2 addresses for external status controls
- Function and endurance tests can be conducted in accordance with local regulations
- Supports patented addressing function ("EZ easy addressing")
- Individual labelling of groups and devices
- Calendar-controlled function and duration test
- Interconnection of up to 25 panels for bigger installations possible

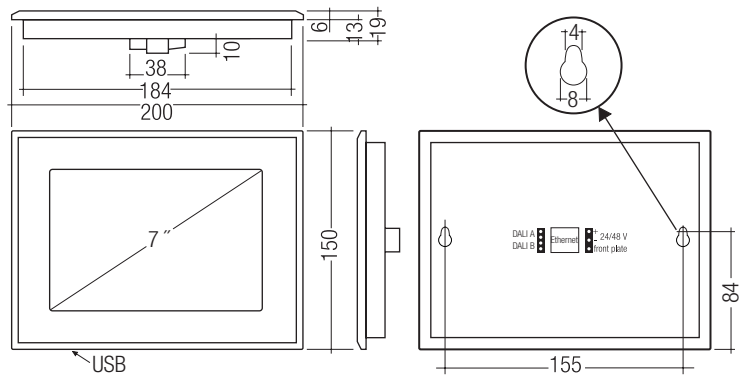

Technical data

Rated supply voltage mains adapter	230 – 240 V
Mains frequency mains adapter	50 / 60 Hz
Rated supply voltage DALI x/e-touchPANEL 02	24 – 48 V DC
Power	10 W
Number of DALI lines	2
Current consumption of each DALI line	2 mA
Ambient temperature t_a	0 ... +50 °C
Touchscreen size	7"
Touchscreen pixel	800 x 640
Colours	64K
Interface	USB, Ethernet
Dimensions L x W x H	200 x 150 x 20 mm
Distance between mounting holes (D)	155 mm
Type of protection	IP20
Housing material	Plastic PA-758

Ordering data

Type	Article number	Packaging, carton
DALI x/e-touchPANEL 02	28000005	1 pc(s).



Standards, page 2

Wiring diagrams and installation examples, page 2

Standards

EN 60950
EN 61347-2-11
EN 61547
EN 62034
EN 55022
EN 55015

Glow-wire test

according to EN 60598-1 passed.

Installation

- DALI is not SELV.
The installation instructions for mains voltage therefore apply.
- External power supply needed (included)
- External DALI bus supply needed (e.g. DALI PS, DALI PS1, ... not included)
- Simple fixing via 2 screws (included)

DALI standard

DALI x/e-touchPANEL 02 is designed to control control gear with DALI standard IEC 60929 (DALI V0) and IEC 62386 (DALI V1).

Lighting management

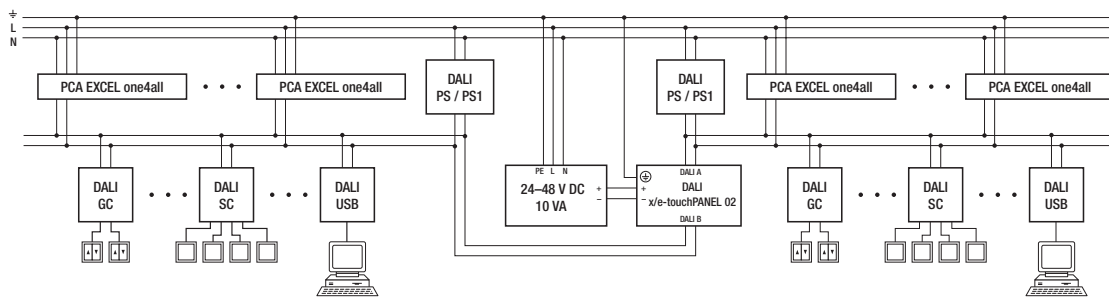

Emergency lighting management

