

## EcoTronic 18–58W 230/240V 50 Hz

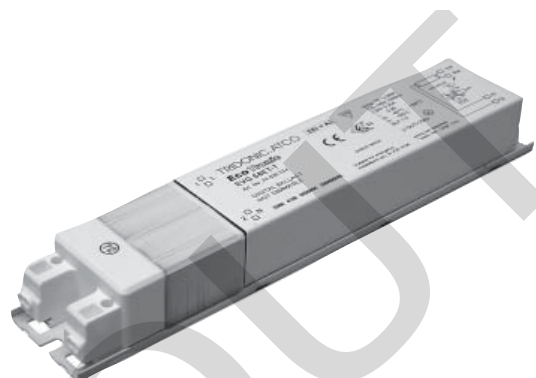
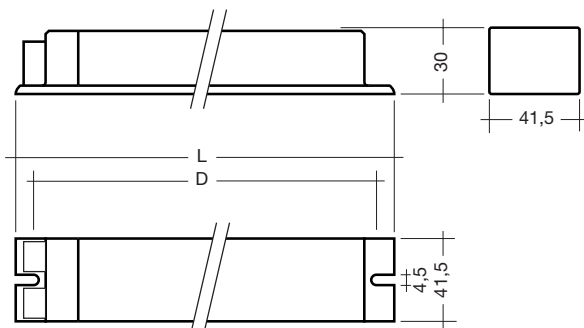

- defined hot lamp restart thanks to intelligent ASIC lamp management
- constant light output independent of fluctuations in mains voltage
- reliable ignition down to -40 °C
- immune to
  - high mains transients
  - large voltage fluctuations
  - temporary overvoltages up to 380V

- quick and reliable switching to emergency lighting with DC operation
- industry-standard EMC
- passive harmonic filter
- automatic re-start after lamp change
- operating frequency  $\geq 42$  kHz
- ingress protection IP 20
- suitable for use in emergency lighting installations in accordance with EN 50172
- dip-coated version for higher protection against condensation water (typical application: outdoor, tunnels)

**Packaging L = 230:**

box of 10  
750 pieces/pallet

**Packaging L = 320:**

box of 10  
500 pieces/pallet

**Approvals:**

EN 61347-2-3  
EN 61347-2-3 AJ  
EN 60929  
EN 61547  
EN 55015: 2006 +  
A1: 2007  
EN 61000-3-2  
EN 61000-3-3  
EN 61347-2-4  
in accordance  
with EN 50172

Lamp		Ballast										
watt- age W	length	type	article number	length L mm	fixing centres D mm	weight kg	circuit power W	lamp power W	current at 230V 50Hz A	$\lambda$	tc point °C	temperature range °C
<b>EcoTronic</b>												
18	590	EcoTronic 18E-T 230/240V 50Hz	24030130	230	220	0,55	19	14	0,09	0,90	85	-40 → +60
2x18	590	EcoTronic 2/18E-T 230/240V 50Hz	24030146	320	310	0,95	38	28	0,18	0,93	85	-40 → +60
36	1200	EcoTronic 36E-T 230/240V 50Hz	24030152	230	220	0,55	39	33	0,18	0,95	85	-40 → +60
2x36	1200	EcoTronic 2/36E-T 230/240V 50Hz	24030165	320	310	0,95	73	66	0,33	0,97	85	-40 → +60
58	1500	EcoTronic 58E-T 230/240V 50Hz	24030171	230	220	0,55	56	51	0,25	0,96	85	-40 → +60
2x58	1500	EcoTronic 2/58E-T 230/240V 50Hz	24030187	320	310	0,95	112	102	0,50	0,96	85	-40 → +60
<b>EcoTronic dip-coated</b>												
18	590	EcoTronic 18ET-T 230/240V 50Hz	24030193	230	220	0,55	19	14	0,09	0,90	85	-40 → +60
2x18	590	EcoTronic 2/18ET-T 230/240V 50Hz	24030203	320	310	0,95	38	28	0,18	0,93	85	-40 → +60
36	1200	EcoTronic 36ET-T 230/240V 50Hz	24030212	230	220	0,55	39	33	0,18	0,95	85	-40 → +60
2x36	1200	EcoTronic 2/36ET-T 230/240V 50Hz	24030228	320	310	0,95	73	66	0,33	0,97	85	-40 → +60
58	1500	EcoTronic 58ET-T 230/240V 50Hz	24030234	230	220	0,55	56	51	0,25	0,96	85	-40 → +60
2x58	1500	EcoTronic 2/58ET-T 230/240V 50Hz	24030240	320	310	0,95	112	102	0,50	0,96	85	-40 → +60

**Electronic ballast**  
**Linear lamps**

**Lamp starting characteristics**

Warm start  
Starting time 1.2 secs with AC and DC operation  
Cathode heating will be reduced after preheat time

**AC operation**

Mains voltage:  
230–240 V 50 Hz  
170–280 V 50 Hz including safety tolerance  
198–300 V 50 Hz including performance tolerance

**DC operation**

230–240 V 0 Hz  
198–320 V 0 Hz certain lamp start  
154–320 V 0 Hz operating range  
Light output level in DC operation: 100 %

**Emergency lighting**

Use in emergency lighting installations according to EN 50172 or for emergency luminaires according to EN 61347-2-3 appendix J.

Instant start after mains interruption < 0.5 s

**Mains currents in DC operation**

type	lamp type	wattage W	mains current at Un = 220 VDC	mains current at Un = 240 VDC
EcoTronic 18E-T 230/240V 50 Hz	T8	18	0.07 A	0.07 A
EcoTronic 36E-T 230/240V 50 Hz	T8	36	0.14 A	0.15 A
EcoTronic 58E-T 230/240V 50 Hz	T8	58	0.19 A	0.20 A
EcoTronic 2/18E-T 230/240V 50 Hz	T8	2x18	0.23 A	0.23 A
EcoTronic 2/36E-T 230/240V 50 Hz	T8	2x36	0.30 A	0.29 A
EcoTronic 2/58E-T 230/240V 50 Hz	T8	2x58	0.41 A	0.42 A

**Harmonic distortion in the mains supply**

type	lamp type	wattage W	THD at 230 V / 50 Hz
EcoTronic 18E-T 230/240V 50 Hz	T8	18	22.9
EcoTronic 36E-T 230/240V 50 Hz	T8	36	24.3
EcoTronic 58E-T 230/240V 50 Hz	T8	58	24.1
EcoTronic 2/18E-T 230/240V 50 Hz	T8	2x18	22.8
EcoTronic 2/36E-T 230/240V 50 Hz	T8	2x36	25.6
EcoTronic 2/58E-T 230/240V 50 Hz	T8	2x58	28.1

**Output voltage**

type	lamp type	wattage W	U <sub>out</sub>
EcoTronic 18E-T 230/240V 50 Hz	T8	18	250
EcoTronic 36E-T 230/240V 50 Hz	T8	36	250
EcoTronic 58E-T 230/240V 50 Hz	T8	58	250
EcoTronic 2/18E-T 230/240V 50 Hz	T8	2x18	250
EcoTronic 2/36E-T 230/240V 50 Hz	T8	2x36	250
EcoTronic 2/58E-T 230/240V 50 Hz	T8	2x58	250

**Ballast lumen factor  
EN 60929 8.1**

type	lamp type	wattage W	AC/DC-BLF at U = 198–254 V, 25 °C and 35 °C
EcoTronic 18E-T 230/240V 50 Hz	T8	18	1.0
EcoTronic 36E-T 230/240V 50 Hz	T8	36	1.0
EcoTronic 58E-T 230/240V 50 Hz	T8	58	1.0
EcoTronic 2/18E-T 230/240V 50 Hz	T8	2x18	1.0
EcoTronic 2/36E-T 230/240V 50 Hz	T8	2x36	1.0
EcoTronic 2/58E-T 230/240V 50 Hz	T8	2x58	1.0

**Ambient Temperature**

-40 °C to +60 °C

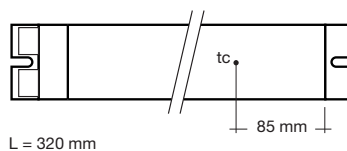
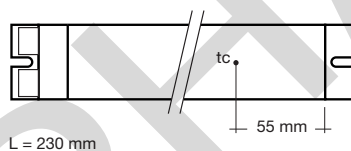

tc point is related to the ballast life duration.  
EcoTronic is designed for an average service life of 50,000 hours under reference conditions and with a failure probability of less than 10 %. This corresponds to an average failure rate of 0.2 % for every 1,000 hours of operation.

**Loading of automatic circuit breakers**

Automatic circuit breaker type	C10	C13	C16	C20	B10	B13	B16	B20
Installation ∅	1.5 mm <sup>2</sup>	1.5 mm <sup>2</sup>	1.5 mm <sup>2</sup>	2.5 mm <sup>2</sup>	1.5 mm <sup>2</sup>	1.5 mm <sup>2</sup>	1.5 mm <sup>2</sup>	2.5 mm <sup>2</sup>
EcoTronic 18E-T 230/240V 50 Hz	76	100	123	153	46	60	73	92
EcoTronic 36E-T 230/240V 50 Hz	46	60	74	93	28	36	44	56
EcoTronic 58E-T 230/240V 50 Hz	33	43	53	66	20	26	32	40
EcoTronic 2/18E-T 230/240V 50 Hz	52	68	84	105	31	41	50	63
EcoTronic 2/36E-T 230/240V 50 Hz	26	34	41	52	15	20	25	31
EcoTronic 2/58E-T 230/240V 50 Hz	16	21	26	32	9	12	15	19

### ASIC light management

ASIC (Application specific integrated circuit) is the very latest in lighting management design technology. The lamp friendly warm start is delivering maximum lamp life and enables high switching frequency applications.

### Wiring advice

The lead length is dependant on the capacitance of the cable. Earthing is not required for the device to operate. Connection to earth reduces radio interference.

Ballast type	Terminal		Maximum capacitance allowed	
	Cold	Hot	Cold	Hot
EcoTronic xE-T	11, 12	5, 6	200 pF	100 pF
EcoTronic 2/xE-T	5, 6, 11, 12	7, 8, 9, 10	200 pF	100 pF

With standard solid wire 0.5/0.75 mm<sup>2</sup> the capacitance of the lead is approx. 80 pF/m. This value is influenced by the way the wiring is made. In borderline cases the capacitance must be measured inside the luminaire. Keep lamp wires short. Lamp connection with twin ballast should be made with symmetrical wiring. Hot leads and cold leads should be separated as much as possible.

### RFI

TridonicAtco ballasts are RFI protected in accordance with EN 55015 and. To operate the luminaire correctly and to minimise RFI we recommend the following instructions:

- Connection to the lamps of the "hot leads" must be kept as short as possible (marked with \*)
- Mains leads should be kept apart from lamp leads (ideally 5–10 cm distance)

- Do not run mains leads adjacent to the electronic ballast
- Twist the lamp leads
- Keep the distance of lamp leads from the metal work as large as possible
- Ballast must be earthed, either over the terminal or over the mounting screw of the ballast
- Mains wiring to be twisted when through wiring
- Keep the mains leads inside the luminaire as short as possible

### Defective lamp

If a lamp is defective, the ballast switches off and goes into standby. There is an automatic restart once the lamp has been changed.

### T8 lamp information

wattage	length
18 W	590 mm
36 W	1200 mm
58 W	1500 mm

### Circuit diagrams

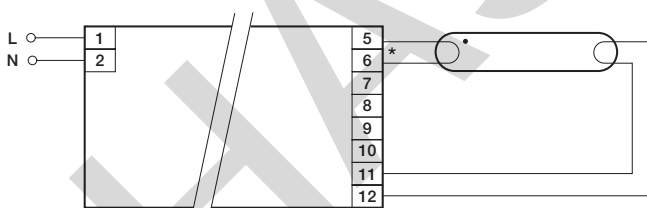

\* keep leads 5, 6 short, max. 1.0 m  
leads 11, 12 max. 3.0 m

EcoTronic 18–58W

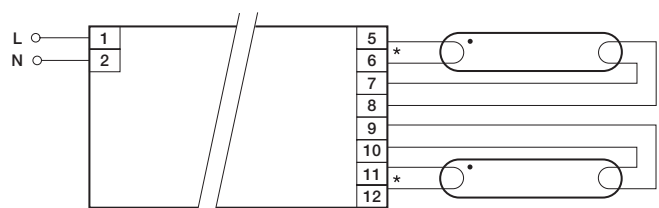

\* keep leads 5, 6, 11, 12 short, max. 1.0 m  
leads 7, 8, 9, 10 max. 3.0 m

EcoTronic 2/18–2/58W