



### DALI-RM/S 4x10A

DALI relays output with 4 independent 10 A switching contacts

#### Product description

- Switching of 4 independent and potential free contacts via DALI
- Max. switching current per contact:  
10 A at ohmic load ( $\cos \varphi = 1$ )<sup>①</sup>
- 1 DALI address per switching contact
- For installation in switching cabinets
- Status LED for indicating the operating status
- Test switch for installation test
- 5-year guarantee

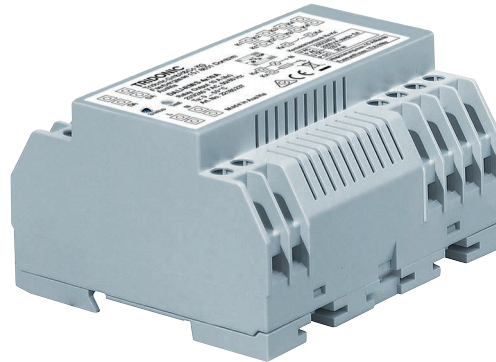

#### Technical data

Rated supply voltage	230 – 240 V
Mains frequency	50 / 60 Hz
Power	< 2 W
Typ. rated current (at 230 V, 50 Hz, all relay contacts open)	10.6 mA
Typ. rated current (at 230 V, 50 Hz, all relay contacts closed)	201 mA
Ambient temperature $t_a$	0 ... +50 °C
Max. casing temperature $t_c$	75 °C
Storage temperature	-20 ... +70 °C
Humidity	5 % ... max. 85 % <sup>②</sup>
Type of protection	IP20

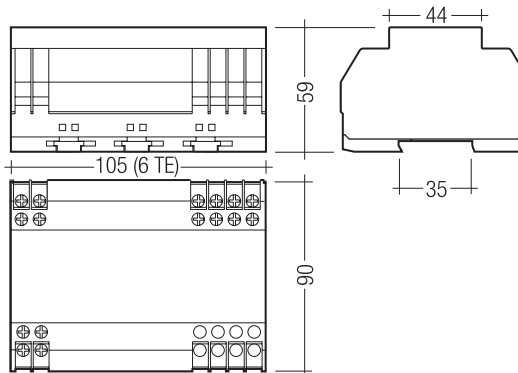

Wiring diagrams and installation examples, page 2

#### Ordering data

Type	Article number	Packaging, carton	Weight per pc.
DALI-RM/S 4x10A	22185237	1 pc(s).	0.46 kg

#### Specific technical data

Type	Inputs			Output, relay		
	DALI control input	Current draw	Number of DALI addresses	Relay, floating	Switching output (at 125 V DC max.)	Switching output (at 240 V AC max.)
DALI-RM/S 4x10A	1	2 mA from DALI	4 (1 per contact)	4 (make contact)	30 W (ohmic load) <sup>①</sup>	2000 W / 10 A (ohmic load) <sup>①</sup>

<sup>①</sup> More loads see load specification on page 2.

<sup>②</sup> Not condensed (max. 56 days/year at 85 %).

**Functional and planning instructions**

DALI-RM/S 4x10A enables switching of 4 independent switching loads via DALI. Lamps and other electronic users with a mains voltage of 230/240 V<sub>AC</sub> can be integrated in a DALI circuit.

- For each DALI scene the 4 contact positions "opened / closed" can be defined separately.
- Default parameters:
  - Control value  $\geq$  DALI DAP 2: contact closes
  - Control value  $\leq$  DALI DAP 1: contact opens
  - Command „Recall min. Level“ contact opens
  - Command „Recall max“ contact closes (permits the identification with the „localisation“ function on masterCONFIGURATOR)
- It is not permitted to connect tapped transformers (e.g. autotransformers) or 3-phase loads (e.g. 3-phase motors) to the DALI RM/S 4x10A because of the risk of a mains short circuit
- Use only in electrical installations that meet EMC regulations.
- No monitoring of loads

**Status LED and momentary-action test switch**

The status LED indicates the operating status of the device and helps to locate faults:

on, flickering occasionally	OK
off, flickering at (4 second) intervals	fault in DALI line (break or short-circuit)
off	no mains voltage
flashing steadily (on/off every 0,5 s)	test mode

**Test mode**

If the momentary-action test switch is pressed for 1 to 5 seconds, all luminaires connected will be switched on. Each time the test switch is subsequently pressed for 1 to 5 seconds, the luminaires are alternately switched on and off. In this way it is possible to check the wiring and operation of the DALI-RM/S 4x10A. The test mode is ended by pressing the momentary-action test switch for more than 5 seconds.

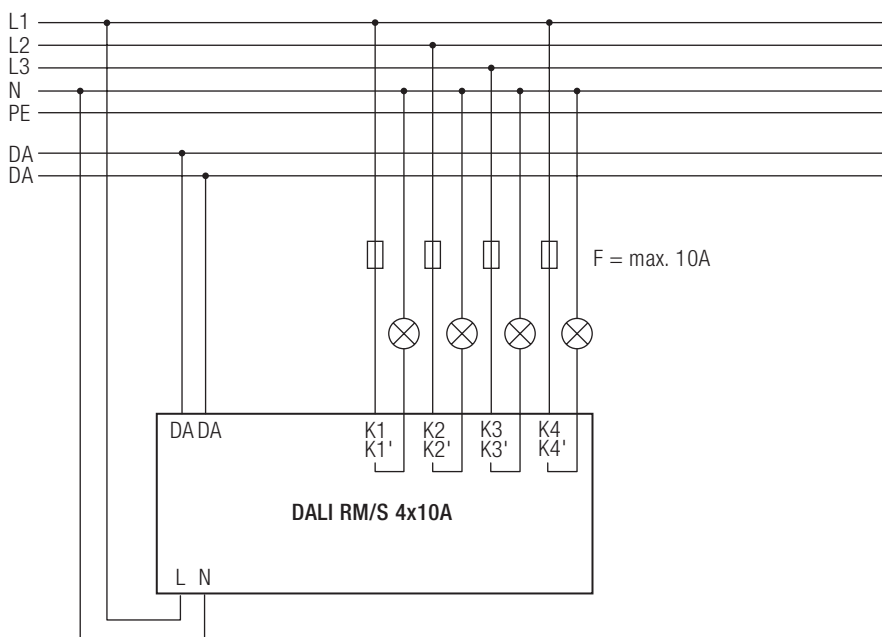
**Wiring diagram****Load specification (designed for 30,000 switching operations)**

- Light bulb: 2,000 W
- High-voltage halogen lamps: 2,000 W
- Fluorescent lamps uncompensated: 1,000 W
- Fluorescent lamps parallel compensated: 920 W / 100  $\mu$ F
- Fluorescent lamps duo circuit: 2 x 1,000 W
- Compact fluorescent lamps uncompensated: 800 W
- Compact fluorescent lamps parallel compensated: 800 W / 100  $\mu$ F
- Low-voltage halogen lamps to magnetic transformers: 400 VA
- Electronic ballasts:
  - as mentioned in manufacturer data for electronic ballasts for automatic circuit breaker type B/10 A
- HID lamps: 800 W / 100  $\mu$ F

**Glow-wire test**

according to EN 60598-1 passed.

**DALI standard**

DALI-RM/S 4x10A is designed to control control gear with DALI standard IEC 60929 (DALI V0).

**Installation**

- Mounting of switching and distribution cabinets on cap rail (35 mm)
- The DALI interface is not SELV.  
The installation instructions for mains voltage therefore apply.
- The maximum cable length of the DALI control signal (for a cable cross-section of 1.5 m<sup>2</sup>) must not be exceeded 300 m or 2 V voltage decrease

**Wiring type and cross section**

The wiring can be solid wire stranded wire with end sleeve with a cross-section of 0.75 mm<sup>2</sup> to 2.5 mm<sup>2</sup>.

