

IP68 

TALEXchain CRYSTAL CLASSIC TALEXchain CRYSTAL

Product description

- LED chain for highlighting lines and edges and for backlighting complex contours, letters and symbols in signage applications
- Optimised for use in signage (lettering, surface backlighting)
- Beam characteristic: 155°
- LED module with plastic casing and strain relief with IP68 protection
- High-power LED in chip-on-board technology (COB)
- Integrated current source to stabilise luminous flux
- Flexible chain, can be split between any module
- Attached with M3 screw or premounted double-sided adhesive tape
- Connection: Cable 180 mm, both sides

Technical data

Ambient temperature t_a	-30 ... +55 °C
Max. surface temperature on module $t_c^{①}$	65 °C
Storage temperature t_s	-30 ... +80 °C
Type of protection ^④	IP68
Risk group (EN 62471:2008)	0



Standards, page 4

Colour temperatures and tolerances, page 5

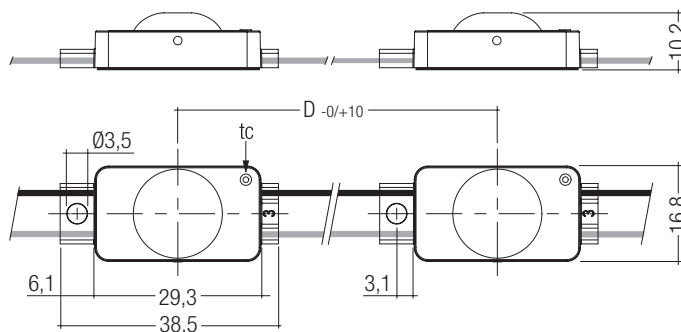
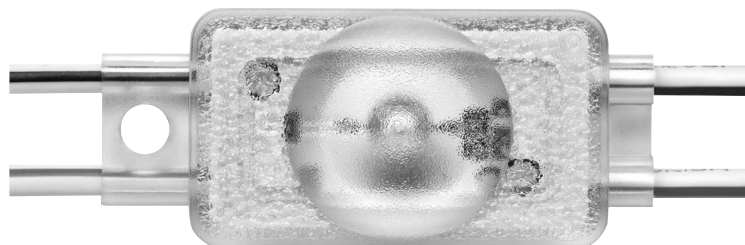

Ordering data

Colour	Wavelength range	Colour temperature	Packing code	Type	Article number
1 light point per module					
Arctic white	–	13.000 K 1		LEDV P540-CLA AW 12 150 10 68 B	22176593
Arctic white	–	13.000 K 2		LEDV P540-CLA AW 12 150 50 68 B	22176587
Arctic white	–	13.000 K 2		LEDV P540-CLA AW 12 100 50 68 B	22176595
Crystal white	–	7.500 K 1		LEDV P540-CLA CW 12 150 10 68 B	22176641
Crystal white	–	7.500 K 2		LEDV P540-CLA CW 12 150 50 68 B	22176647
Crystal white	–	7.500 K 2		LEDV P540-CLA CW 12 100 50 68 B	22176644
Daylight white	–	6.500 K 1		LEDV P540-CLA DL 12 150 10 68 B	22176642
Daylight white	–	6.500 K 2		LEDV P540-CLA DL 12 150 50 68 B	22176648
Daylight white	–	6.500 K 2		LEDV P540-CLA DL 12 100 50 68 B	22176645
Gold white	–	2.700 K 1		LEDV P540-CLA GW 12 150 10 68 B	22176544
Gold white	–	2.700 K 2		LEDV P540-CLA GW 12 150 50 68 B	22176545
Gold white	–	2.700 K 2		LEDV P540-CLA GW 12 100 50 68 B	22176546
Red	626 – 636 nm	–	1	LEDV P540-CLA R 12 150 10 68 B	22176643
Red	626 – 636 nm	–	2	LEDV P540-CLA R 12 150 50 68 B	22176649
Red	626 – 636 nm	–	2	LEDV P540-CLA R 12 100 50 68 B	22176646
Green	525 – 540 nm	–	1	LEDV P540-CLA G 12 150 10 68 B	22176692
Green	525 – 540 nm	–	2	LEDV P540-CLA G 12 150 50 68 B	22176694
Green	525 – 540 nm	–	2	LEDV P540-CLA G 12 100 50 68 B	22176693
Blue	455 – 460 nm	–	1	LEDV P540-CLA B 12 150 10 68 B	22176697
Blue	455 – 460 nm	–	2	LEDV P540-CLA B 12 150 50 68 B	22176699
Blue	455 – 460 nm	–	2	LEDV P540-CLA B 12 100 50 68 B	22176698
Orange	600 – 610 nm	–	1	LEDV P540-CLA O 12 150 10 68 B	22176702
Orange	600 – 610 nm	–	2	LEDV P540-CLA O 12 150 50 68 B	22176704
Orange	600 – 610 nm	–	2	LEDV P540-CLA O 12 100 50 68 B	22176703

Packaging code 1: 1 piece/bag, 100 pieces/carton, 600 pieces/pallet

Packaging code 2: 1 piece/bag, 45 pieces/carton, 270 pieces/pallet

Specific technical data

Type	Photometric code	Wavelength range	Colour temperature	Typ. luminous flux per module ^②	Colour rendering index CRI ^②	Supply voltage DC ^③	Typ. current per module ^②	Typ. power per module	Luminous efficacy
1 light point per module									
LEDV P540-CLA AW		–	13,000 K	22 lm	73	12 V	23 mA	0.28 W	78 lm/W
LEDV P540-CLA CW	775/789, 875/789	–	7,500 K	24 lm	73	12 V	23 mA	0.28 W	85 lm/W
LEDV P540-CLA DL	775/789, 875/789	–	6,500 K	24 lm	73	12 V	23 mA	0.28 W	85 lm/W
LEDV P540-CLA NW	742/789, 842/789, 942/789	–	4,200 K	21 lm	80	12 V	23 mA	0.28 W	82 lm/W
LEDV P540-CLA GW	742/789, 842/789, 942/789	–	2,700 K	13 lm	> 90	12 V	29 mA	0.35 W	37 lm/W
LEDV P540-CLA R		– 626 – 636 nm	–	9 lm	–	12 V	30 mA	0.36 W	25 lm/W
LEDV P540-CLA G		– 525 – 540 nm	–	20 lm	–	12 V	20 mA	0.24 W	93 lm/W
LEDV P540-CLA B		– 455 – 460 nm	–	3 lm	–	12 V	18 mA	0.22 W	14 lm/W
LEDV P540-CLA LB		–	–	13 lm	–	12 V	35 mA	0.42 W	31 lm/W
LEDV P540-CLA O		– 600 – 610 nm	–	17 lm	–	12 V	34 mA	0.40 W	43 lm/W
LEDV P540-CLA A		– 584 – 594 nm	–	17 lm	–	12 V	36 mA	0.43 W	40 lm/W

^① If the max. temperature limits are exceeded, the life of the module will be greatly reduced or the module may be damaged.
For the precise position of the tc point see the above diagram.

^② Tolerance range for optical and electrical data: ±15 % (optical data for blue: ±30 %, green: +15 / -30 %; electrical data for red, orange, amber: +15 / -30 %).

^③ Exceeding the max. operating voltage leads to an overload on the TALEXchain.
This may in turn result in a reduction in lifetime or even in destruction.
Tolerance range for the supply voltage: 12 V: +2 V / -0 V.

^④ Maximum submerge depth 1 m / 60 min.

All values at ta = 25 °C.

Product configurator

The products listed on page 1 are a predefined selection of possible product configurations.
The product configurator also offers the option of configuring chains optimized for the particular application:
The light colour, module spacing, number of modules and beam characteristics can be selected.

Selection parameters

Colour	Arctic white AW Crystal white CW Daylight white DL Neutral white NW Gold white GW Red R Green G Blue B Light blue LB Orange O Amber A
Module distance D	90 – 300 mm in 10 mm steps
Number of modules	10 ^① , 20 – 100 in 1 piece steps ^②
Beam characteristic	140° (A), 155° (B)

^① Packaging code 1: 1 piece/bag, 100 pieces/carton, 600 pieces/pallet.

^② Packaging code 2: 1 piece/bag, 45 pieces/carton, 270 pieces/pallet.

Type code

Example: LEDV P540-CLA CW 12 150 10 68 B

LEDV P540-CLA	TALEXchain CRYSTAL CLASSIC
CW	Colour = crystal white
12	Supply voltage = 12 V
150	Module distance D = 150 mm
10	Number of modules = 10
68	Type of protection = IP68
B	Beam characteristic = 155°

For more information please call or email your Tridonic contact.

Photometric code

Key for photometric code, e. g. 830 / 559

1 st digit	2 nd + 3 rd digit	4 th digit	5 th digit	6 th digit
Code CRI	Colour temperature in Kelvin x 100	McAdams initial	McAdams after 25% of the lifetime (max.6000h)	Lumen maintenance after 25% of the lifetime (max.6000h)
7 67 – 76				Code Remaining lumen
8 77 – 86				7 ≥ 70 %
9 87 – ≥90				8 ≥ 80 % 9 ≥ 90 %

Converter matrix – TALEXchain CRYSTAL CLASSIC

IN-BUILT LCU ^①							REMOTE LCU ^②			
Type	LCU 015/12 D010	LCU 035/12 D010	LCU 035/12 D210	LCU 060/12 D010	LCU 100/12 D010	LCU 150/12 D010	LCU 035/12 E020	LCU 060/12 E020	LCU 100/12 E020	LCU 150/12 E020
Article number	24166316	24166318	25000670	24166322	24166326	24166331	24166319	24166323	24166327	24166332

Assignable converter

Assignable converter

Type	Number of modules												Number of modules								Max. chaining
	Min.	Max.	Min.	Max.	Min.	Max.	Min.	Max.	Min.	Max.	Min.	Max.	Min.	Max.	Min.	Max.	Min.	Max.			
LEDV P540-CLA AW	5	46	17	108	17	108	24	186	47	310	93	465	14	108	24	186	47	310	93	465	50
LEDV P540-CLA CW	5	46	17	108	17	108	24	186	47	310	93	465	14	108	24	186	47	310	93	465	50
LEDV P540-CLA DL	5	46	17	108	17	108	24	186	47	310	93	465	14	108	24	186	47	310	93	465	50
LEDV P540-CLA NW	5	46	17	108	17	108	24	186	47	310	93	465	14	108	24	186	47	310	93	465	50
LEDV P540-CLA GW	4	37	13	86	13	86	19	149	37	248	74	372	12	86	19	149	37	248	74	372	50
LEDV P540-CLA R	4	36	13	84	13	84	18	144	36	241	72	362	11	84	18	144	36	241	72	362	50
LEDV P540-CLA G	6	54	19	126	19	126	27	217	54	362	108	543	17	126	27	217	54	362	108	543	50
LEDV P540-CLA B	6	59	21	138	21	138	30	237	59	395	118	592	18	138	30	237	59	395	118	592	50
LEDV P540-CLA LB	4	31	11	72	11	72	16	124	31	207	62	310	10	72	16	124	31	207	62	310	50
LEDV P540-CLA O	4	32	12	76	12	76	17	130	33	217	65	326	10	76	17	130	33	217	65	326	50
LEDV P540-CLA A	4	30	11	70	11	70	16	121	31	202	61	303	10	70	16	121	31	202	61	303	50

^① Type of protection IP67

^② Type of protection IP20

Standards

- EN 62031
- EN 62471

The product meets the “inbuilt LED module” classification according to EN 62031. The product passed the glow-wire test with 650 °C according to EN 62031. The product passed the salt spray test (degree of severity: 6) according to EN 60068-2-52-1.

Certificates

- UL file: e313318
- CSA certificate: 249699
- ENEC for light colours AW, CW, DL, GW only

Thermal behaviour

operation temperature (operation, no defects)	ta	- 30 → + 55 °C
storage temperature	ts	- 30 → + 80 °C
max. temperature tc point	tc	- 30 → + 65 °C

The values apply to operation at 100 % output, natural convection. If the maximum temperature limits are exceeded, the life of the module will be greatly reduced. The module can fail within a short time. The tc point temperature of the module has to be measured in the thermally stable state and under operating conditions. Measurement setup e.g. according to IEC/EN 60598-1.

tc temperature in °C	Luminous flux in %	Life time in h
15	80	32,000
	70	52,000
	50	100,000
35	80	30,000
	70	50,000
	50	95,000
65	80	25,000
	70	45,000
	50	80,000

Label product

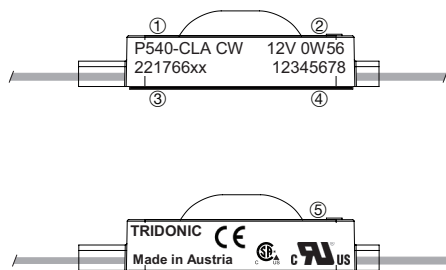

- ① Type
- ② Electr. specification
- ③ Article code
- ④ Production batch
- ⑤ Normative symbols

Wiring

Cable: AWG 18

Colour	red-white	black-white
Function	+	-

Wiring example

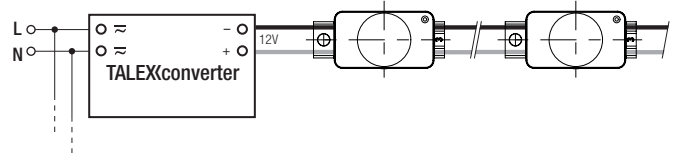

Empirical values for decrease of luminous flux over the chain

Colour	Module distance 100 mm	Module distance 150 mm	Module distance 200 mm	Module distance 300 mm	Number of modules
Arctic white	0%	0%	0%	0%	50
Crystal white	0%	0%	0%	0%	50
Daylight white	0%	0%	0%	0%	50
Neutral white	0%	0%	0%	0%	50
Gold white	0%	0%	0%	0%	50
Red	0%	0%	0%	0%	50
Green	11%	15%	19%	27%	50
Blue	0%	0%	0%	0%	50
Light blue	0%	2%	4%	14%	50
Orange	0%	0%	0%	0%	50
Amber	0%	0%	0%	0%	50

Heat value

0.23 MJ/module

Maintenance note

The product is maintenance free. If cleaning during application only clear water without the addition of cleaning agents should be used.

Label product packaging

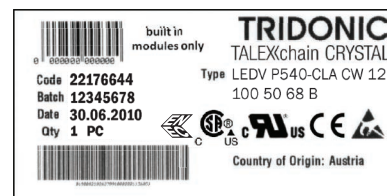

Label carton

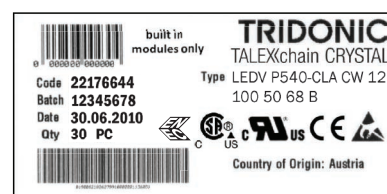

Beam characteristics 155°

Light distribution I_v/I_{vmax} .

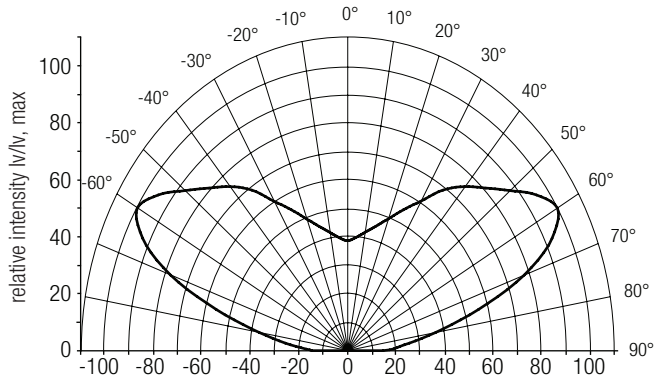

Beam characteristics 140°

Light distribution I_v/I_{vmax} .

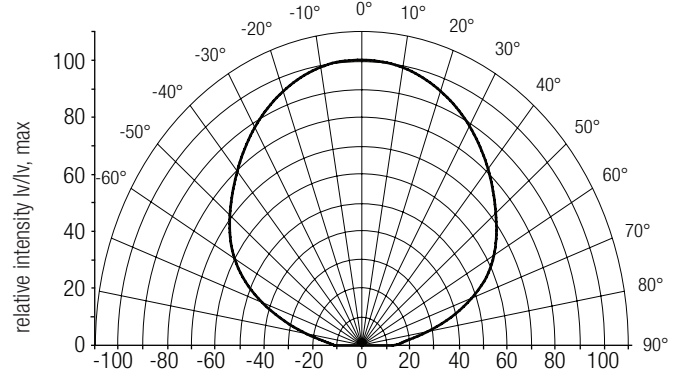

Coordinates and tolerances according to CIE 1964

Arctic white

13,000 K

	x0	y0
Centre	0.2769	0.2732

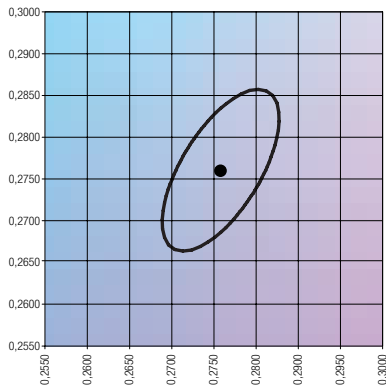

MacAdam ellipse: 5SDCM

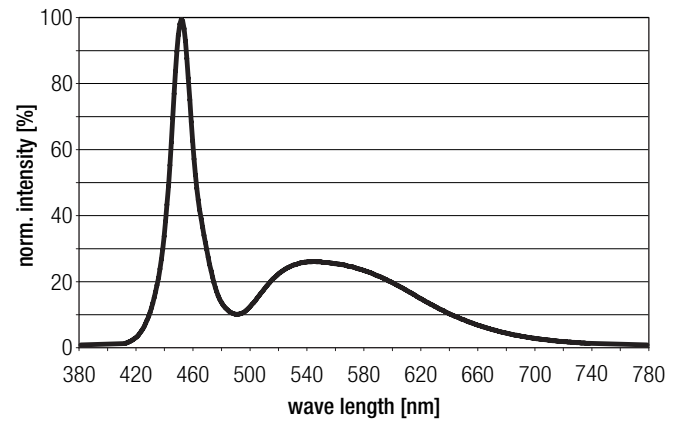

Crystal white

7,500 K

	x0	y0
Centre	0.3106	0.3124

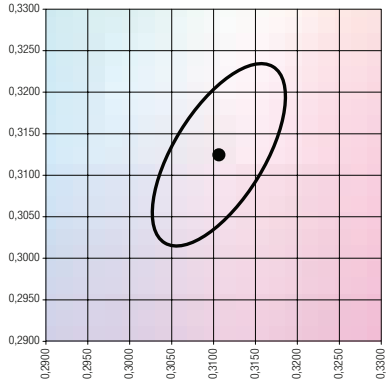

MacAdam ellipse: 5SDCM

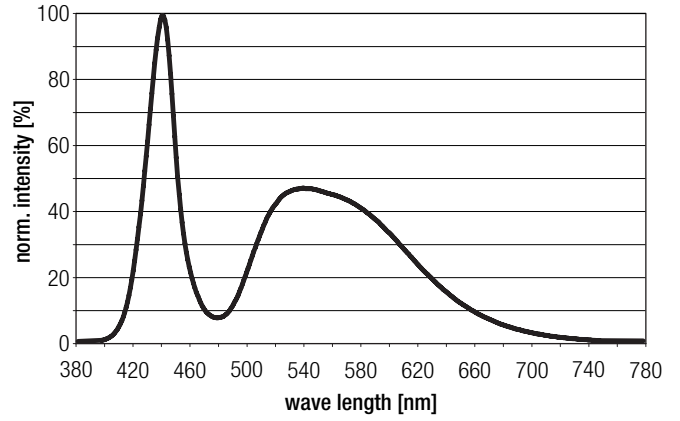

Daylight white

6,500 K

	x0	y0
Centre	0.3230	0.3310

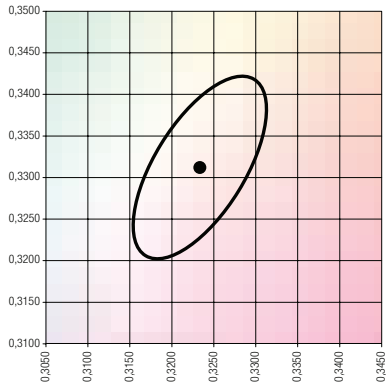

MacAdam ellipse: 5SDCM

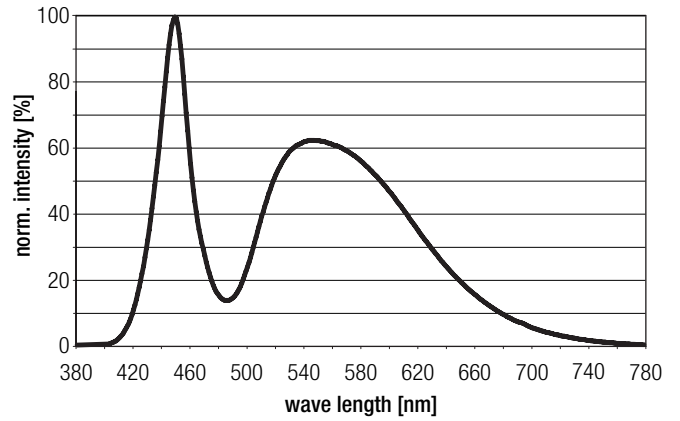

Neutral white

4,200 K

	x0	y0
Centre	0.3833	0.3733

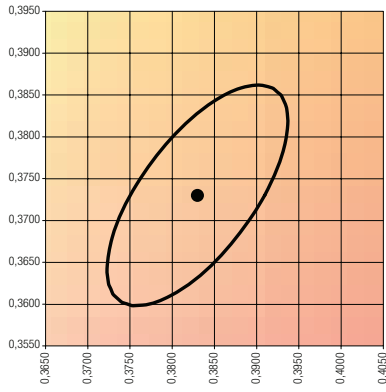

MacAdam ellipse: 5SDCM

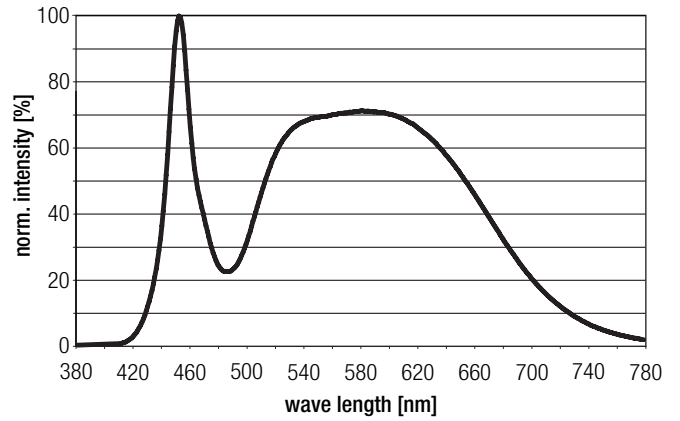

Gold white

2,700 K

	x0	y0
Centre	0.4740	0.4186

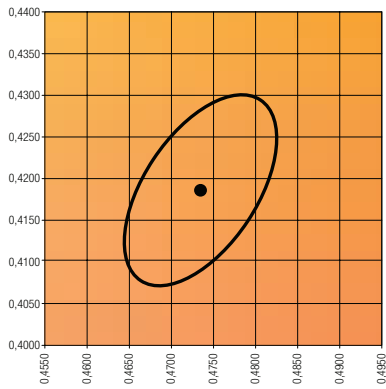

MacAdam ellipse: 5SDCM

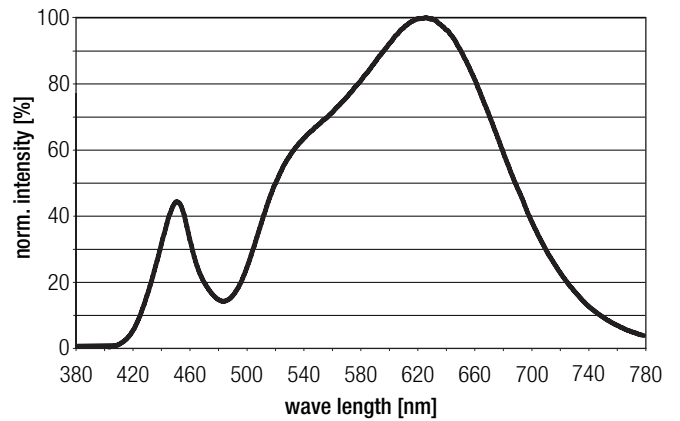

Light blue

	x	y
A	0,1886	0,2961
B	0,2010	0,2961
C	0,2060	0,3161
D	0,1936	0,3161

